

Flywheel Alternators By Engine Model

MODEL	DESCRIPTION	PART NO.
AENL	10 amp alternator circuit	ENA123
AENL	25 amp alternator circuit	ENA124
AGND	25 amp alternator circuit	ENA102
AGND	10 amp alternator circuit	ENA103
S10D, S12D, S14D	10 amp alternator circuit	ENA127
S10D, S12D, S14D	25 amp alternator circuit	ENA128
THD, TJD	25 amp alternator circuit	ENA100
THD, TJD	10 amp alternator circuit	ENA101
MVF4D	15 amp-24 volt alternator circuit	ENB101
VE4D, VF4D	30 amp alternator circuit	ENA100
VE4D, VF4D	10 amp alternator circuit	ENA101
VG4D	25 amp alternator circuit	ENA120
VG4D	10 amp alternator circuit	ENA121
VG4D	Obsolete 10 amp/25 amp alternator circuit	— — —
VG4D	30 amp alternator circuit	ENA132
VH4D	30 amp alternator circuit	ENA100
VH4D	10 amp alternator circuit	ENA101
VH4D	25 amp alternator circuit	ENA120
VH4D	10 amp alternator circuit	ENA121
VH4D	30 amp alternator circuit	ENA132
W2-1230, W2-1235,		
W2-1250	30 amp alternator circuit	ENA130
W2-880	25 amp alternator circuit	ENA100
W2-880	10 amp alternator circuit	ENA101
W4-1770	25 amp alternator circuit	ENA120
W4-1770	10 amp alternator circuit	ENA121
W4-1770	30 amp alternator circuit	ENA132

Flywheel Alternators By Part Number

PART NO.	DESCRIPTION	MODEL
ENA100	25 amp alternator circuit	THD, TJD
ENA101	10 amp alternator circuit	THD, TJD
Obsolete	10 amp alternator circuit	THD, TJD
ENA100	25 amp alternator circuit	W2-880
ENA101	10 amp alternator circuit	W2-880
ENA100	30 amp alternator circuit	VE4D, VF4D, VH4D
ENA101	10 amp alternator circuit	VE4D, VF4D, VH4D
ENA102	25 amp alternator circuit	AGND
ENA103	10 amp alternator circuit	AGND
ENA120	25 amp alternator circuit	W4-1770, VH4D
ENA121	10 amp alternator circuit	W4-1770, VH4D
ENA120	25 amp alternator circuit	VG4D
ENA121	10 amp alternator circuit	VG4D
Obsolete	10 amp/25 amp alternator previous to serial no. 5188288	VG4D
ENA123	10 amp alternator circuit	AENL
ENA124	25 amp alternator circuit	AENL
ENA127	10 amp alternator circuit	S10D, S12D, S14D
ENA128	25 amp alternator circuit	S10D, S12D, S14D
ENA130	30 amp alternator circuit	W2-1230, W2-1235, W2-1250
ENA132	30 amp alternator circuit	VH4D, VG4D, W4-1770
Obsolete	10 amp/30 amp alternator circuits	All Models
ENB101	15 amp-24 volt alternator circuits	MVF4D

ENA100 (25 Amp), ENA101 (10 Amp) Flywheel Alternators

USE WITH MODEL W2-880

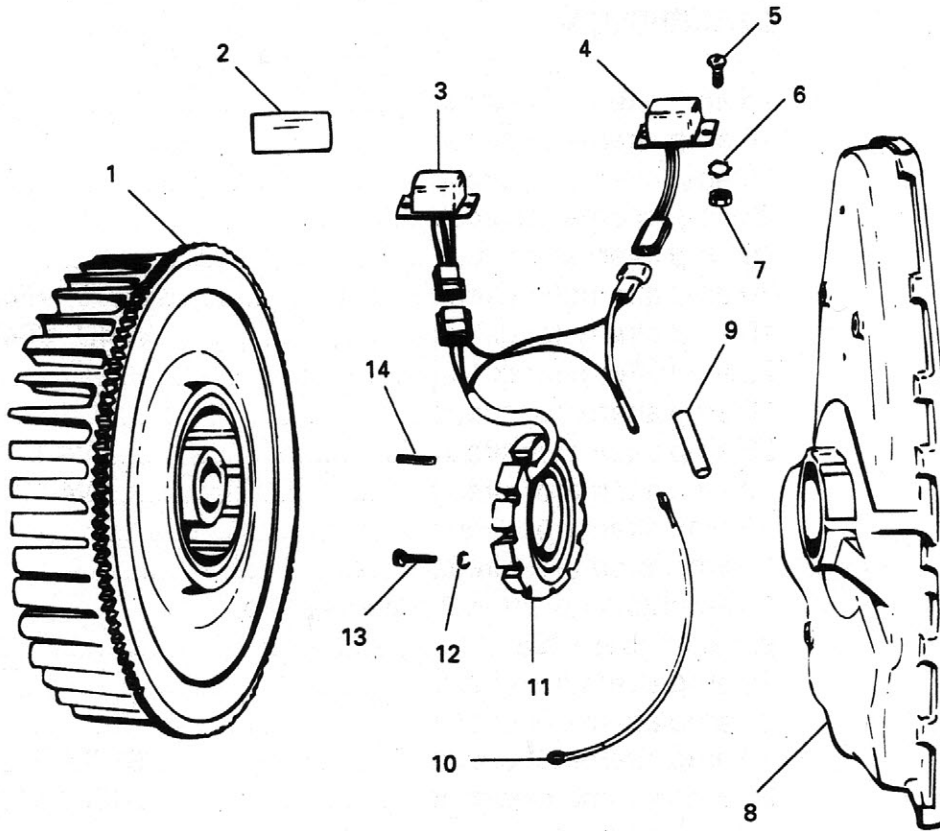

ITEM	PART NO.	DESCRIPTION	QTY	ITEM	PART NO.	DESCRIPTION	QTY
1	N102-5	Flywheel assembly, 10 amp (includes rotor and ring gear)	1	10	YL381-14	Wire assembly, 10 amp	1
—	N102-9	Flywheel assembly, 25 amp (includes rotor and ring gear)	1	—	YL380-14	Wire assembly, 25 amp	1
2	SD293	Decal	1	11	YB81	Stator assembly, 10 amp, 3/8" wide	1
3	YJ68	Rectifier	1	—	YB82	Stator assembly, 25 amp, 5/8" wide	1
4	YJ60	Regulator module	1	12	PE14	Lock washer, no. 10	4
5	XA8	Screw, no. 10-32 thread x 1/2" long	4	13	XB113	Screw, 10 amp, no. 10-32 thread x 3/4" long	4
6	PE78A	Lock washer, no. 10	4	—	XB106	Screw, 25 amp, no. 10-32 thread x 1" long	4
7	PD115	Nut, no. 10-32 thread	4	14	PA368	Roll pin, 10 amp, 3/16 x 7/8" long	2
8	BD103J1S1	Gear cover assembly, W2-880	1	—	PA340	Roll pin, 25 amp, 3/16 x 1-1/8" long	2
9	YD350	Ammeter wire insulator	1				

ENA100 (12 Volt - 25 Amp), ENA101 (12 Volt - 10 Amp) Flywheel Alternators

USE WITH MODELS TH, THD, TJD

NOTE: Beginning with engine serial no. 5188288 a new two module alternator system replaces the previously furnished three module system that included an isolation diode module, and the two unit system without the isolation diode. The Rectifier module and stator assembly have been modified and are not interchangeable with the old unless both are changed. The obsolete parts are identified by serial number.

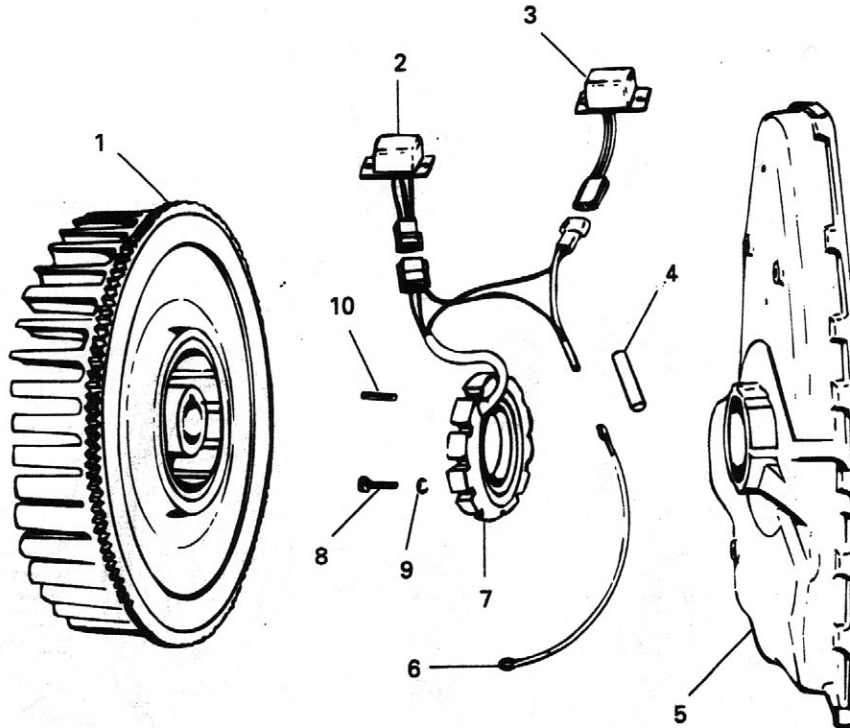

ITEM	PART NO.	DESCRIPTION	QTY	ITEM	PART NO.	DESCRIPTION	QTY
1	N102-5	Flywheel, 10 amp (includes rotor and ring gear)	1	5	BD103JS1	Gear cover assembly	1
—	N102-9	Flywheel, 25 amp (includes rotor and ring gear)	1	6	YL381-14	Wire assembly, 10 amp	1
2	YJ68	Rectifier module	1	—	YL380-14	Wire assembly, 25 amp	1
—	YJ58	Rectifier module (previous to serial no. 5188288)	1	7	YB81	Stator assembly, 10 amp	1
—	YJ67	Isolation diode (not illustrated) (on engines previous to serial no. 5188288)	1	—	YB75	Stator assembly, 10 amp (previous to serial no. 5188288)	1
3	YJ59	Regulator module, 10 amp ...	1	—	YB82	Stator assembly, 25 amp	1
—	YJ60	Regulator module, 25 amp ...	1	—	YB76	Stator assembly, 25 amp (previous to serial no. 5188288)	1
4	YD350	Insulator	1	8	XB113	Screw, 10 amp	4
				—	XB106	Screw, 25 amp	4
				9	PE14	Lock washer, no. 10	4
				10	PA368	Roll pin, 10 amp	2
				—	PA340	Roll pin, 25 amp	2

**ENA100 (12 Volt - 25 Amp), ENA101 (12 Volt - 10 Amp)
Flywheel Alternators With Combination Rectifier-Regulator (Obsolete)**

USE WITH MODELS TH, THD, TJD

NOTE: Beginning with engine serial no. 5188288 a new two module alternator system replaces the previously furnished three module system that included an isolation diode module, and the two unit system without the isolation diode. The Rectifier module and stator assembly have been modified and are not interchangeable with the old unless both are changed. The obsolete parts are identified by serial number.

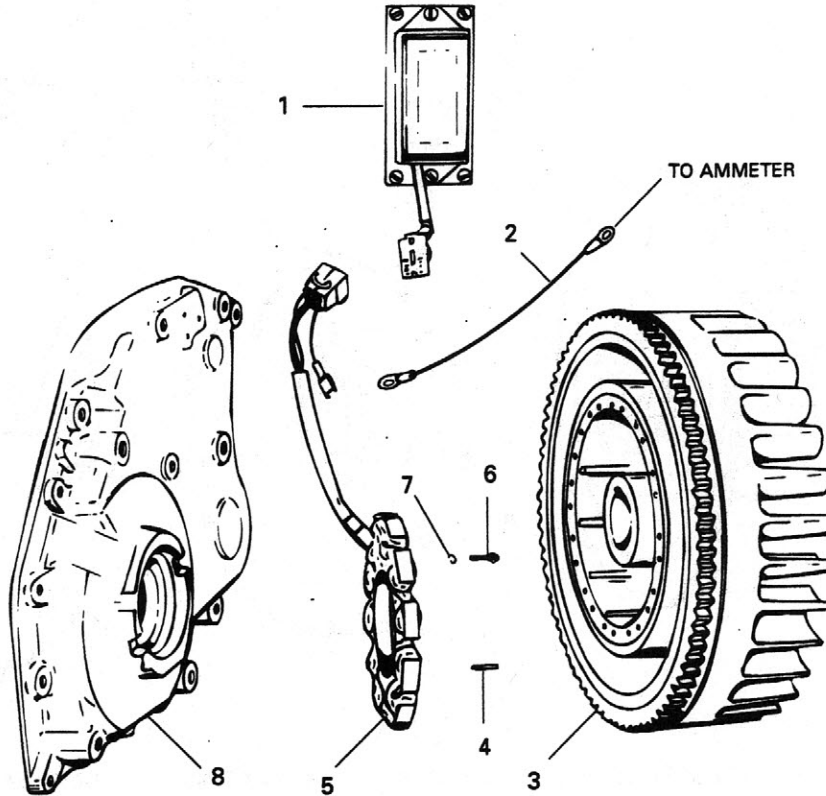

ITEM	PART NO.	DESCRIPTION	QTY
1	YJ56	Rectifier-regulator module ...	1
2	YL381-14	Wire assembly	1
3	N102-5	Flywheel assembly (includes magnetic rotor and ring gear)	1
—	SE135AK5	Flywheel shroud (not illustrated)	1
4	PA368	Roll pin	2
5	YB72	Stator assembly	1
6	XB113	Screw, no. 10-32 thread	4
7	PE14	Lock washer, no. 10	4
8	BD103JS1	Gear cover assembly	1

**ENA100 (12 Volt – 30 Amp), ENA101 (12 Volt – 10 Amp)
Flywheel Alternators (Obsolete)**

USE WITH MODELS VE4D, VF4D, VH4D

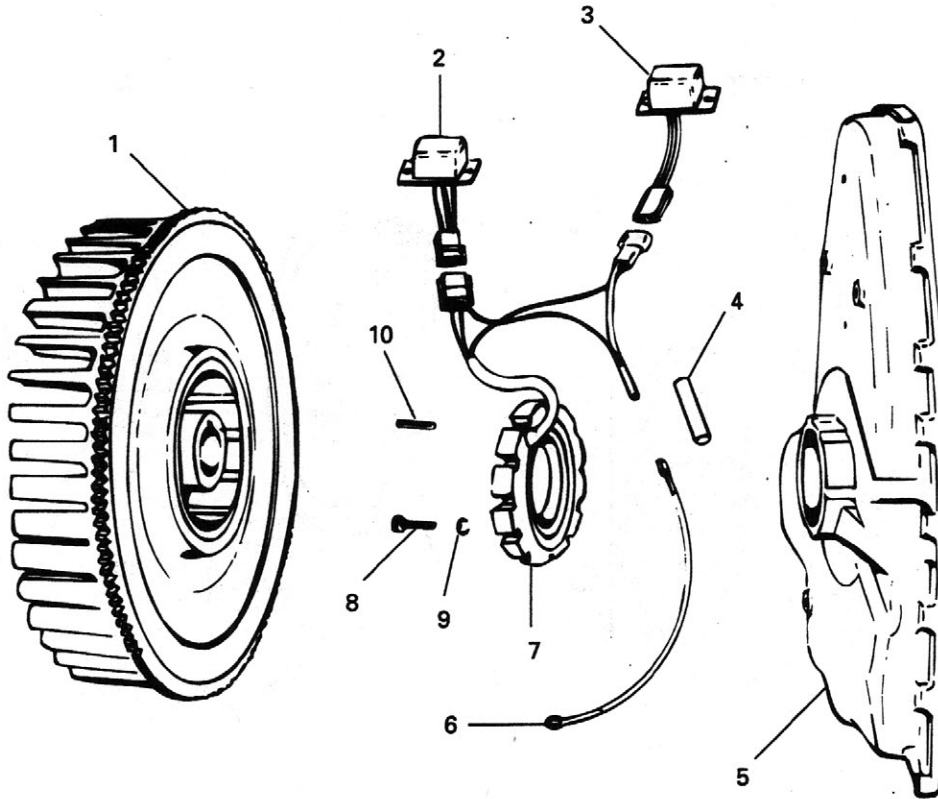

ITEM	PART NO.	DESCRIPTION	QTY	ITEM	PART NO.	DESCRIPTION	QTY
1	N101-6	Flywheel, 10 amp (includes rotor and ring gear)	1	7	YB75	Stator assembly, 10 amp	1
—	N101-10	Flywheel, 30 amp (includes rotor and ring gear)	1	—	YB76	Stator assembly, 30 amp	1
2	YJ58	Rectifier module	1	8	XB113	Screw, 10 amp	4
3	YJ59	Regulator module, 10 amp ...	1	—	XB106	Screw, 30 amp	4
—	YJ60	Regulator module, 30 amp ...	1	9	PE14	Lock washer, no. 10	4
4	YD350	Insulator	1	10	PA368	Roll pin, 10 amp	2
5	BD100K4S1	Gear cover assembly	1	—	PA340	Roll pin, 30 amp	2
6	YL381-14	Wire assembly, 10 amp	1	—	PD115	Nut, no. 10-32 thread (not illustrated)	4
—	YL380-14	Wire assembly, 30 amp	1	—	PE78A	Lock washer, no. 10 (not illustrated)	4
				—	XA8	Screw, no. 10-32 thread (not illustrated)	4

ENA100 (12 Volt), ENA101 (12 Volt) Flywheel Alternators (Obsolete)

USE WITH MODELS VE4D, VF4D, VH4D

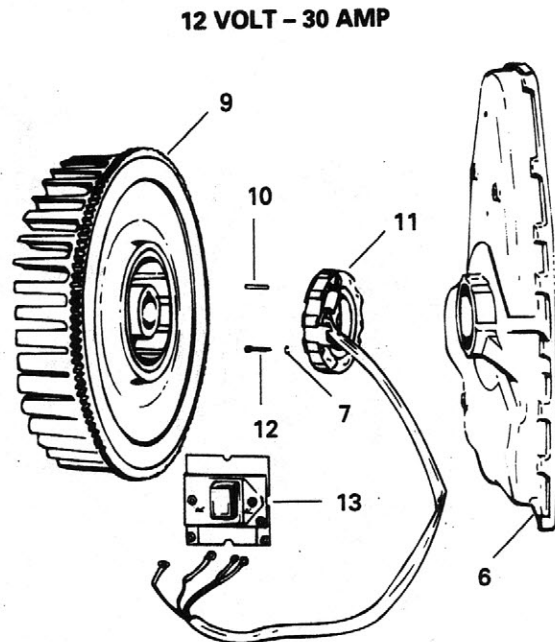
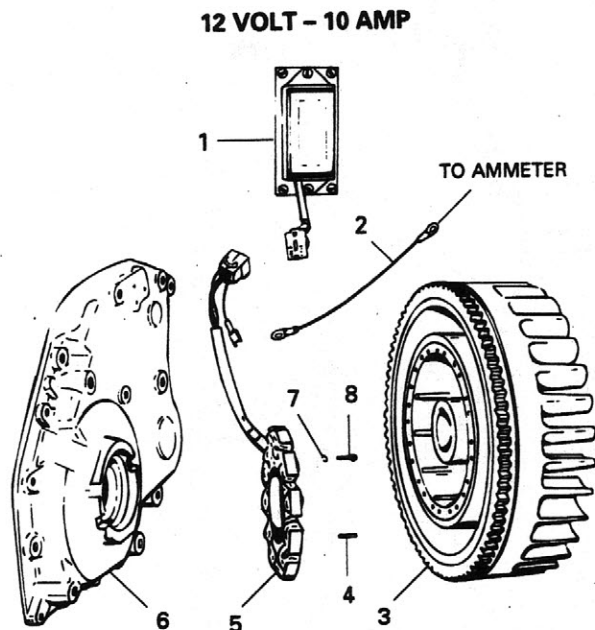

ITEM	PART NO.	DESCRIPTION	QTY	ITEM	PART NO.	DESCRIPTION	QTY
1	YJ56	Rectifier-regulator module, 10 amp	1	7	PE14	Lock washer, no. 10	4
2	YL381-18	Wire assembly, 10 amp	1	8	XB113	Screw, 10 amp	4
3	N101-6	Flywheel, 10 amp (includes magnetic rotor and ring gear)	1	9	N101	Flywheel, 30 amp	1
4	PA368	Roll pin, 10 amp	2	10	PA340	Roll pin, 30 amp	2
5	YB72	Stator assembly, 10 amp	1	11	YB67	Stator assembly, 30 amp	1
6	BD100K4S1	Gear cover assembly	1	12	XB106	Screw, 30 amp	4
				13	YJ49S1	Rectifier-regulator module, 30 amp	1

ENA102 (25 Amp), ENA103 (10 Amp) Flywheel Alternators

USE WITH MODEL AGND

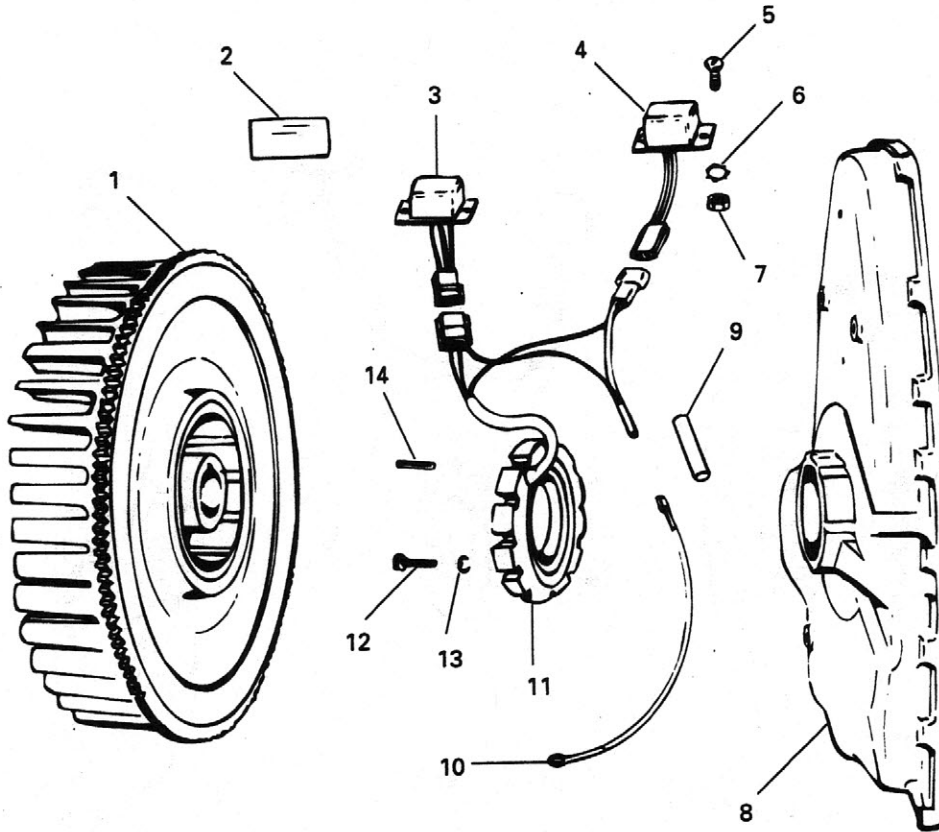

ITEM	PART NO.	DESCRIPTION	QTY	ITEM	PART NO.	DESCRIPTION	QTY
1	N103-5	Flywheel assembly, 10 amp (includes rotor and ring gear)	1	10	YL381-18	Wire assembly, 10 amp	1
—	N103-9	Flywheel assembly, 25 amp (includes rotor and ring gear)	1	—	YL380-18	Wire assembly, 25 amp	1
2	SD293	Decal	1	11	YB81	Stator assembly, 10 amp, 3/8" wide	1
3	YJ68	Rectifier module	1	—	YB82	Stator assembly, 25 amp	1
4	YJ60	Regulator module	1	12	XB 113	Screw, 10 amp, no. 10-32 thread x 3/4" long	4
5	XA7	Screw, no. 10-32 thread x 1/2" long	4	—	XB106	Screw, 25 amp, no. 10-32 thread x 1" long	4
6	PE78A	Lock washer, no. 10	4	13	PE14	Lock washer, no. 10	4
7	PD115	Nut, no. 10-32 thread	4	14	PA368	Roll pin, 10 amp, 3/16 x 7/8	2
8	BG343S1	Bearing retainer plate	1	—	PA340	Roll pin, 25 amp, 3/16 x 1-1/8	2
9	YD350	Insulator	1				

ENA120 (25 Amp), ENA121(10 Amp) Flywheel Alternators

USE WITH MODELS W4-1770, VH4D

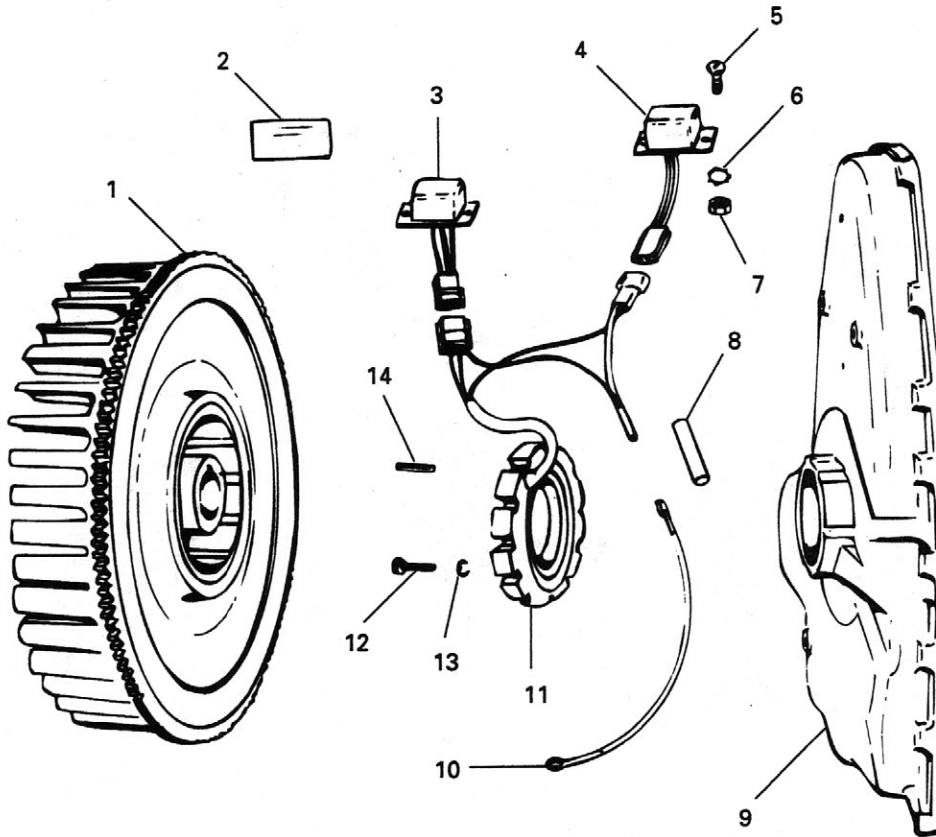

ITEM	PART NO.	DESCRIPTION	QTY	ITEM	PART NO.	DESCRIPTION	QTY
1	N101-17	Flywheel assembly, 10 amp, W4-1770 (includes rotor and ring gear)	1	10	YL381-18	Wire assembly, 10 amp	1
—	N101-16	Flywheel assembly, 25 amp, W4-1770 (includes rotor and ring gear)	1	—	YL380-18	Wire assembly, 25 amp	1
2	SD293	Decal	1	11	YB81	Stator assembly, 10 amp, 3/8" wide flange	1
3	YJ68	Rectifier module	1	—	YB82	Stator assembly, 25 amp	1
4	YJ60	Regulator module	1	12	XB113	Screw, 10 amp, no. 10-32 thread x 3/4" long	4
5	XA8	Screw, no. 10-32 thread x 1/2" long	4	—	XB106	Screw, 25 amp, no. 10-32 thread x 1" long	4
6	PE78A	Lock washer, no. 10	4	13	PE14	Lock washer, no. 10	4
7	PD115	Nut, no. 10-32 thread	4	14	PA368	Roll pin, 10 amp, 3/16 x 7/8 long	2
8	YD350	Insulator	1	—	PA340	Roll pin, 25 amp, 3/16 x 1-1/8 long	2
9	BD100M1S1	Gear cover assembly	1				

ENA120 (25 Amp), ENA121(10 Amp) Flywheel Alternators
USE WITH MODEL VG4D

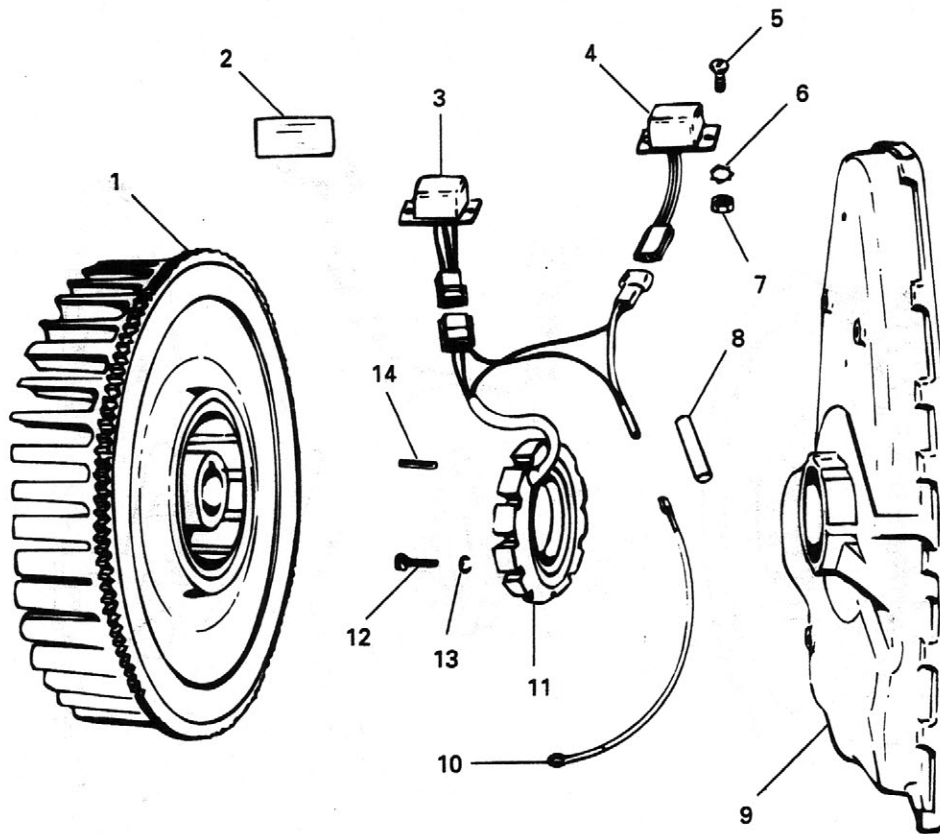

ITEM	PART NO.	DESCRIPTION	QTY	ITEM	PART NO.	DESCRIPTION	QTY
1	N100-5	Flywheel assembly, 10 amp (includes rotor and ring gear)	1	10	YL381-22	Wire assembly, 10 amp	1
—	N100-9	Flywheel assembly, 25 amp (includes rotor and ring gear)	1	—	YL380-22	Wire assembly, 25 amp	1
2	SD293	Decal	1	11	YB81	Stator assembly, 10 amp, 3/8" wide flange	1
3	YJ68	Rectifier module	1	—	YB82	Stator assembly, 25 amp	1
4	YJ60	Regulator module	1	12	XB113	Screw, 10 amp, no. 10-32 thread x 3/4" long	4
5	XA8	Screw, no. 10-32 thread x 1/2" long	4	—	XB106	Screw, 25 amp, no. 10-32 thread x 1" long	4
6	PE78A	Lock washer, no. 10	4	13	PE14	Lock washer, no. 10	4
7	PD115	Nut, no. 10-32 thread	4	14	PA368	Roll pin, 10 amp, 3/16 x 7/8	2
8	YD350	Insulator	1	—	PA340	Roll pin, 25 amp, 3/16 x 1-1/8	2
9	BD101BS1	Gear cover assembly	1				

Flywheel Alternator (Obsolete) (On Engines Previous To Serial No. 5188288)

USE WITH MODEL VG4D

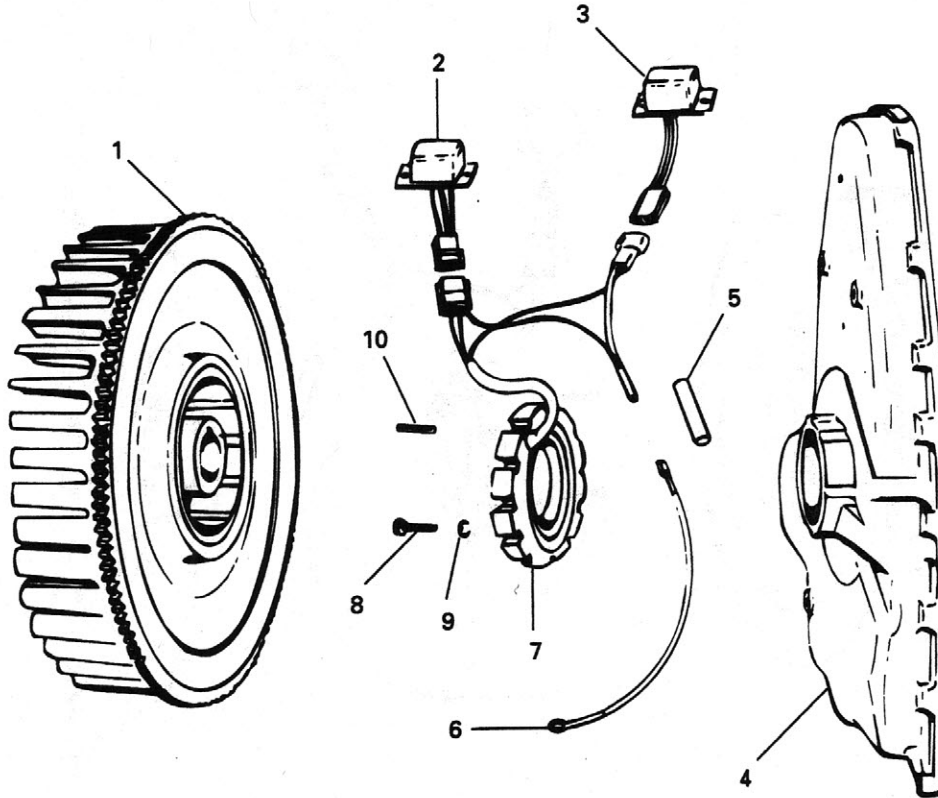

ITEM	PART NO.	DESCRIPTION	QTY	ITEM	PART NO.	DESCRIPTION	QTY
1	N100-5	Flywheel, 10 amp (includes rotor and ring gear)	1	—	YB76	Stator assembly, 30 amp	1
—	N100-9	Flywheel, 30 amp (includes rotor and ring gear)	1	8	XB113	Screw, 10 amp	4
2	YJ58	Rectifier module	1	—	XB106	Screw, 30 amp	4
3	YJ59	Regulator module, 10 amp ...	1	9	PE14	Lock washer, no. 10	4
—	YJ60	Regulator module, 30 amp ...	1	10	PA368	Roll pin, 10 amp	2
4	BD101BS1	Gear cover assembly	1	—	PA340	Roll pin, 30 amp	2
5	YD350	Insulator	1	—	PD115	Nut, no. 10-32 thread (not illustrated)	4
6	YL381-18	Wire assembly, 10 amp	1	—	PE78A	Lock washer, no. 10 (not illustrated)	4
—	YL380-18	Wire assembly, 30 amp	1	—	XA8	Screw, no. 10-32 thread (not illustrated)	4
7	YB75	Stator assembly, 10 amp	1				

Flywheel Alternator (Obsolete)

USE WITH MODEL VG4D

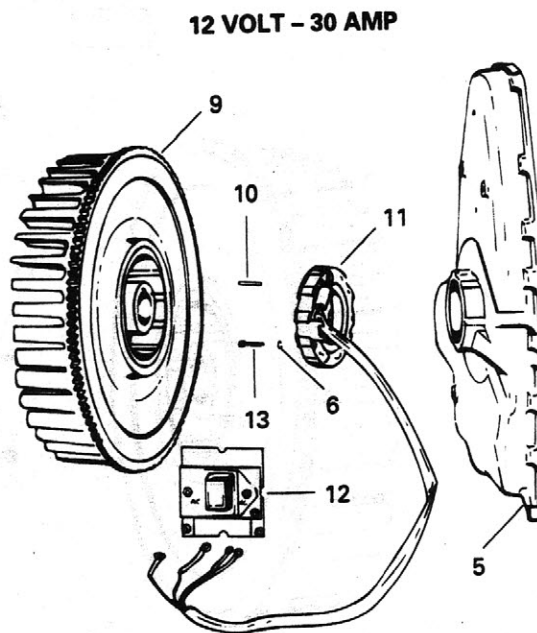
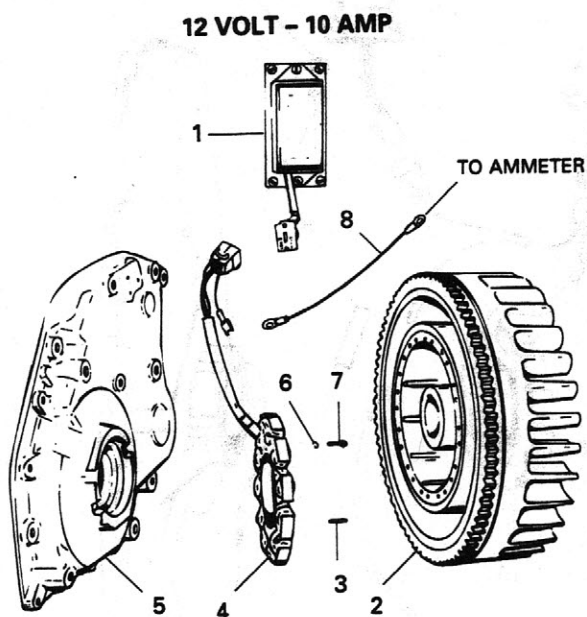

ITEM	PART NO.	DESCRIPTION	QTY	ITEM	PART NO.	DESCRIPTION	QTY
1	YJ56	Rectifier-regulator module, 10 amp	1	8	YL381-18	Wire assembly, 10 amp	1
2	N100-5	Flywheel, 10 amp (includes rotor and ring gear)	1	9	N100	Flywheel, 30 amp (includes rotor and ring gear)	1
3	PA368	Roll pin, 10 amp	2	10	PA340	Roll pin, 30 amp	2
4	YB72	Stator assembly, 10 amp	1	11	YB67	Stator assembly, 30 amp	1
5	BD101BS1	Gear cover assembly	1	12	YJ49S1	Rectifier-regulator module, 30 amp	1
6	PE14	Lock washer, no. 10	4	13	XB106	Screw, 30 amp	4
7	XB113	Screw, 10 amp	4				

ENA123 (10 Amp), ENA124 (25 Amp) Flywheel Alternators

USE WITH MODEL AENL

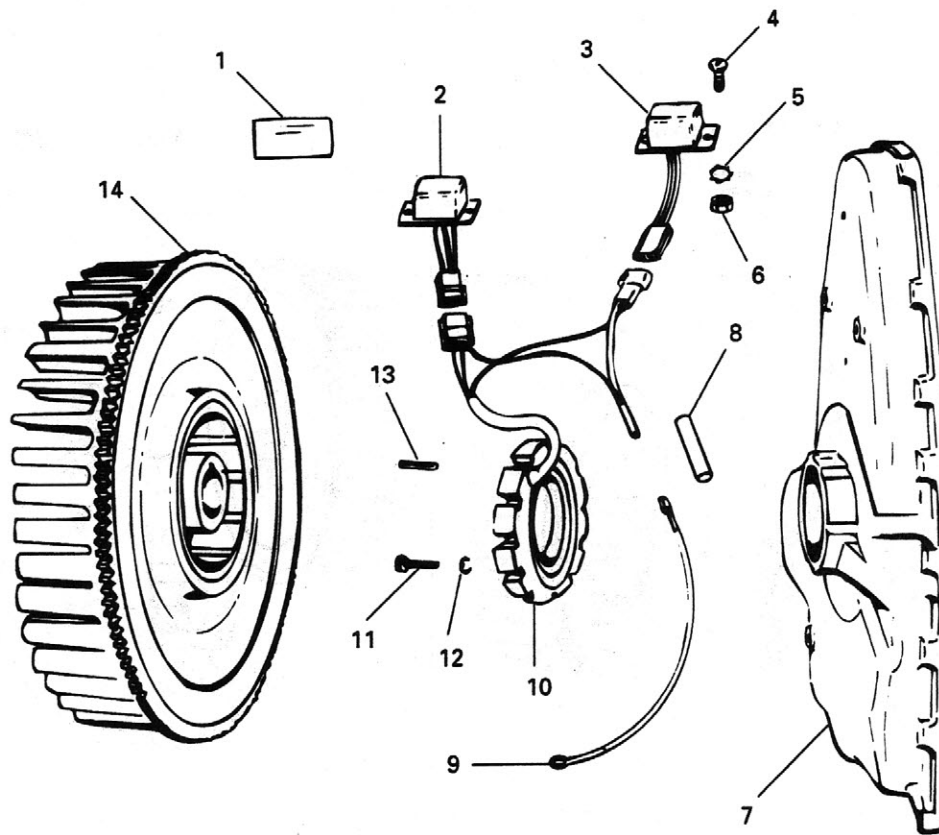

ITEM	PART NO.	DESCRIPTION	QTY	ITEM	PART NO.	DESCRIPTION	QTY
1	SD293	Decal.....	1	—	XB110	Screw, 25 amp, no. 10-32 thread x 1" long	4
2	YJ68	Rectifier module	1	12	PE14	Lock washer, no. 10	4
3	YJ60	Regulator module	1	13	PA336	Roll pin, 10 amp, 3/16 x 7/8	2
4	XA7	Screw, no. 10-32 thread x 1/2" long	4	—	PA362	Roll pin, 25 amp, 3/16 x 1-1/8	2
5	PE78A	Lock washer, no. 10	4	14	N108-2	Flywheel assembly, 10 amp (includes rotor and ring gear)	1
6	PD115	Nut, no. 10-32 thread	4	—	N108-3	Flywheel assembly, 25 amp (includes rotor and ring gear)	1
7	BG344S1	Bearing retainer plate	1				
8	YD350	Insulator	1				
9	YL381-6	Wire assembly, 10 amp	1				
—	YL380-6	Wire assembly, 25 amp	1				
10	YB81	Stator assembly, 10 amp, 3/8" wide flange	1				
—	YB82	Stator assembly, 25 amp	1				
11	XB114	Screw, 10 amp, no. 10-32 thread x 3/4" long	4				

ENA127 (10 Amp), ENA128 (25 Amp) Flywheel Alternators

USE WITH MODELS S10D, S12D, S14D

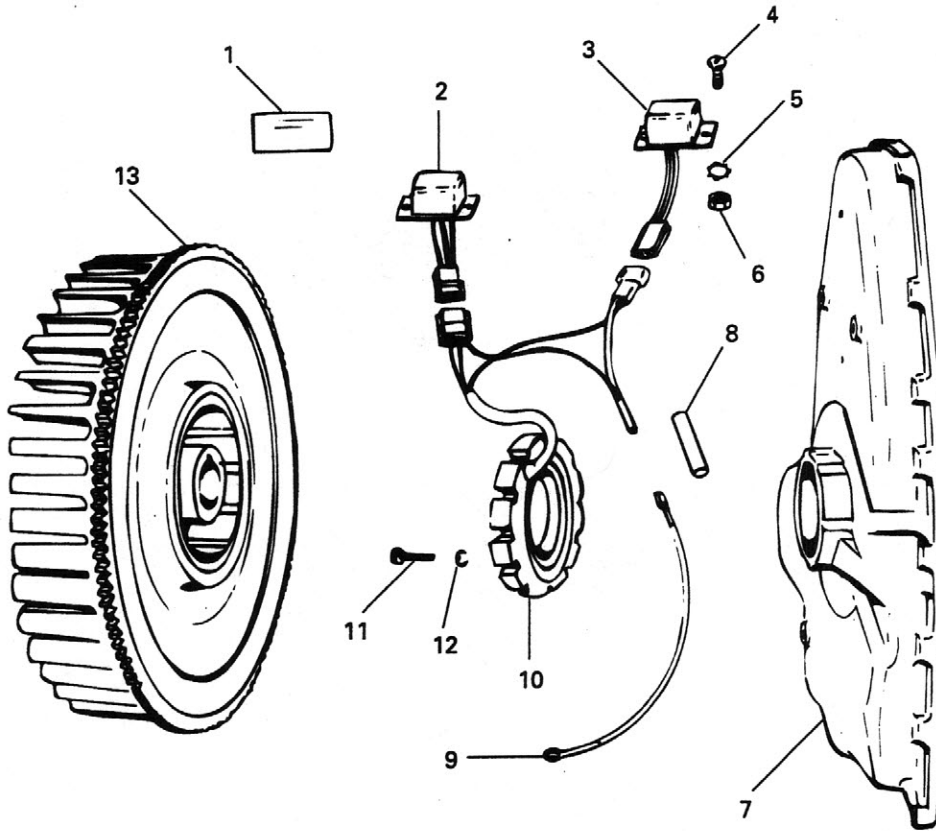

ITEM	PART NO.	DESCRIPTION	QTY	ITEM	PART NO.	DESCRIPTION	QTY
1	SD293	Decal	1	—	YB82	Stator assembly, 25 amp	1
2	YJ68	Rectifier module	1	11	XB113	Screw, 10 amp, no. 10-32 thread x 3/4" long	4
3	YJ60	Regulator module	1	—	XB106	Screw, 25 amp, no. 10-32 thread x 1" long ...	4
4	XA7	Screw, no. 10-32 thread x 1/2" long	4	12	PE14	Lock washer, no. 10	4
5	PE78A	Lock washer, no. 10	4	13	N105A2	Flywheel assembly, 10 amp (includes rotor and ring gear)	1
6	PD115	Nut, no. 10-32 thread	4	—	N105A3	Flywheel assembly, 25 amp (includes rotor and ring gear)	1
7	BG350AS1	Bearing retainer plate	1				
8	YD350	Insulator	1				
9	YL381-18	Wire assembly, 10 amp	1				
—	YL380-18	Wire assembly, 25 amp	1				
10	YB81	Stator assembly, 10 amp, 3/8" wide flange	1				

ENA130 (30 Amp) Flywheel And Flywheel Alternator
USE WITH MODELS W2-1230, W2-1235, W2-1250

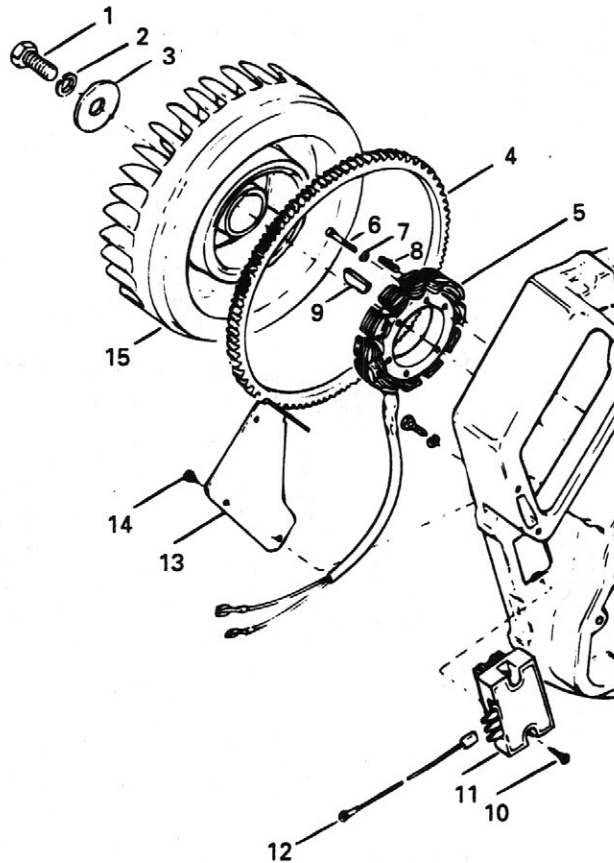

ITEM	PART NO.	DESCRIPTION	QTY	ITEM	PART NO.	DESCRIPTION	QTY
—	ENA130	Flywheel alternator assembly (includes 5-8, 10-14)	1	11	YJ70	Rectifier/regulator module ...	1
1	XD51	Screw, 5/18"-11 thread x 1-1/4" long	1	12	YL393-24	Wire assembly	1
2	PE37	Lock washer, 5/8"	1	13	SA163	Cover	1
3	PH610	Washer, 5/8" I.D. x 2-1/8 x 3/16"	1	14	XA129	Screw, no. 10 thread x 1/2" long	3
4	GH57	Ring gear	1	15	N111-3	Flywheel assembly (includes 1GH57, 1NC217-3, 1YN5, 1PA470) (optional)	1
5	YB84	Alternator stator assembly ...	1	—	N113-4	Flywheel assembly with tap holes	1
6	XB114	Screw, no. 10-32 thread x 1-1/4" long	4	—	N114-2	Flywheel assembly without alternator magnetic rotor (includes item 4)	1
7	PE14	Lock washer, no. 10	4	—	N114-3	Flywheel assembly with tap holes	1
8	PA340	Roll pin, 3/16" x 1-1/8" long	2				
9	PL17	No. 13 Woodruff key	1				
10	XA77	Screw, no. 10 thread x 5/8" long	2				

ENA132 (30 Amp) Flywheel And Flywheel Alternator

USE WITH MODELS VH4D, VG4D, W4-1770

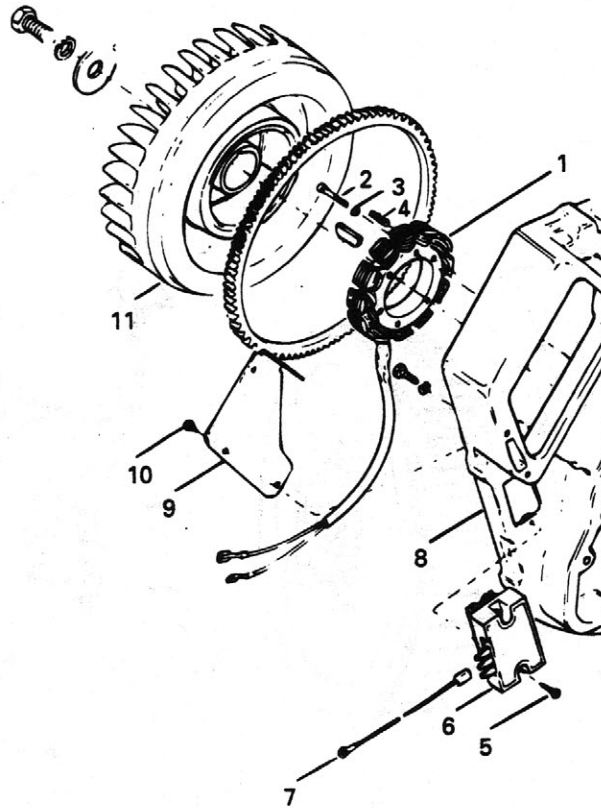

ITEM	PART NO.	DESCRIPTION	QTY	ITEM	PART NO.	DESCRIPTION	QTY
—	ENA132	Flywheel alternator assembly (includes 1-7, 9, 10)	1	11	N101E16	Flywheel assembly, VH4D	1
1	YB84	Alternator stator assembly ...	1	—	SE74YA	Air shroud, VH4D (not illustrated)	1
2	XB106	Screw, no. 10-32 thread x 1" long	4	—	SE76B11	Lower air shroud, VH4D (not illustrated)	1
3	PE14	Lock washer, no. 10	4	—	N101E16	Flywheel assembly, W4-1770	1
4	PA340	Roll pin, 3/16" x 1-1/8" long	2	—	SE74YA	Air shroud, W4-1770 (not illustrated)	1
5	XA35	Screw, 1/4-20 thread x 5/8" long	2	—	SE76B11	Lower air shroud, W4-1770 (not illustrated)	1
6	YJ70	Rectifier/regulator module ...	1	—	N100D9	Flywheel assembly, VG4D	1
7	YL393-24	Wire assembly	1	—	SE124AM	Air shroud, VG4D (not illustrated)	1
8	BD100K4S1	Gear cover, VH4D	1	—	SE126A14	Lower air shroud, VG4D (not illustrated)	1
—	BD100M1S1	Gear cover, W4-1770	1				
—	BD101BS1	Gear cover, VG4D	1				
9	SA163	Cover	1				
10	XA129	Screw, no. 10 thread x 1/2" long	3				

ENB101 (24 Volt – 15 Amp) Flywheel Alternator

USE WITH MODELS MVF4D, MVH4D

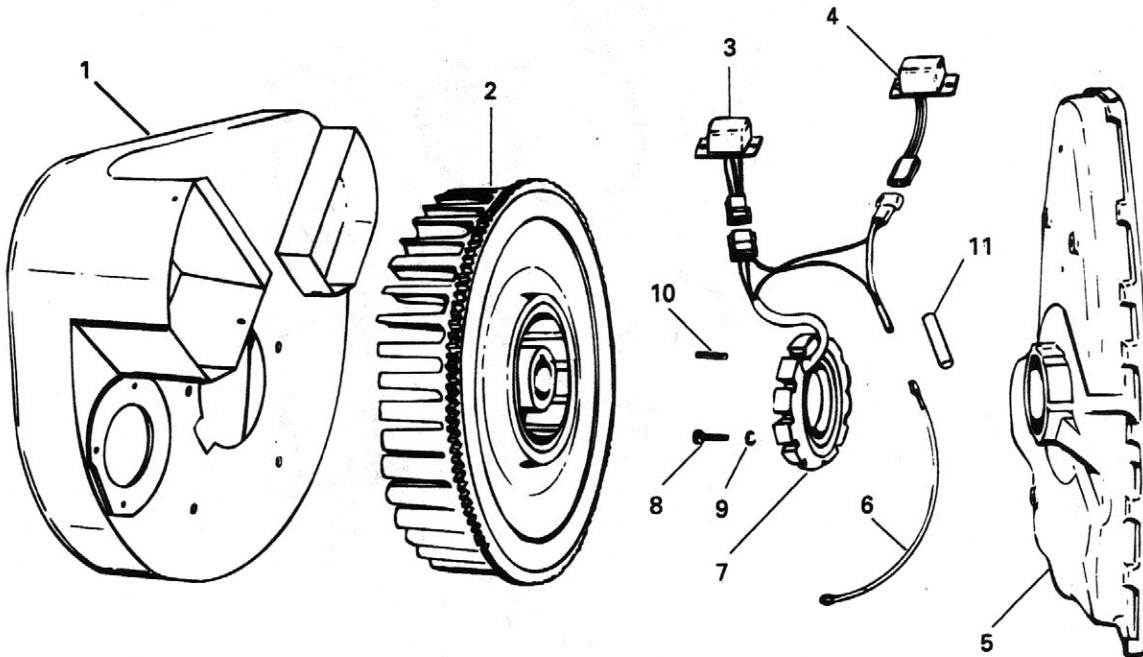

ITEM	PART NO.	DESCRIPTION	QTY	ITEM	PART NO.	DESCRIPTION	QTY
1	SE74YA	Flywheel shroud	1	9	PE14	Lock washer, no. 10	4
2	N101-10	Flywheel	1	10	PA340	Roll pin	2
3	YJ64	Rectifier module, 24 volt	1	11	YD350	Insulator	1
4	YJ65	Regulator module, 24 volt	1	—	PD115	Nut, no. 10-32 thread (not illustrated)	4
5	BD100K6S1	Gear cover assembly	1	—	PE78A	Lock washer, no. 10 (not illustrated)	4
6	YL380-14	Wire assembly	1	—	XA8	Screw, no. 10-32 thread (not illustrated)	4
7	YB79	Stator assembly, 24 volt, 15 amp	1				
8	XB106	Screw	4				

ENB101 (24 Volt – 15 Amp) Flywheel Alternator

The flywheel alternator, Fig. 1, is a permanent magnet type and has *no brushes, commutator, belts or adjustments*. A series of coils (stator) is mounted to the engine gear cover, and the magnetic flux is provided by a permanent magnet in the flywheel which rotates around these stationary coils. Four components make up this light weight – space saving source of energy: a *flywheel* with magnetic rotor, *stator*, *rectifier* module and *regulator* module.

The *center-top* rectifier arrangement prevents damage to the alternator system, in the event of incorrect battery connection or from arc welding. One half of the load-producing winding is in series with each diode, so when the battery is connected in reverse, resistance of the winding limits the current draw and keeps it at a safe level. If the incorrect battery connection is not remedied, complete drainage of the battery occurs, but the rectifier will not be damaged.

In the case of arc welding, the winding acts as a choke and its inductance prevents the transient voltage from damaging the diodes.

PRECAUTIONS to be exercised in the use of this flywheel alternator:

1. **Do Not** reverse battery connections. This is for a *negative ground* system only.
2. Connect booster batteries properly – positive to positive and negative to negative.
3. **Do Not** polarize the alternator.
4. **Do Not** ground any wires from stator or modules which terminate at connectors.
5. **Do Not** operate engine with battery disconnected from system.
6. Disconnect at least one battery lead if a fast battery charger is used.
7. Never use a fast battery charger to boost the battery output.

WIRING CIRCUIT (Fig. 2)

The *fool-proof* type connectors used, prevent incorrect wiring from the stator to the rectifier and regulator modules. To disconnect plugs, squeeze outer ends of receptacle and pull apart.

The rectifier and regulator modules are grounded to the engine and therefore should not be removed and mounted at some remote location. This is a *negative ground circuit*. Connect ground strap from negative post of battery to starting motor flange, or good clean grounding surface on engine.

ENB101 (24 Volt - 15 Amp) Flywheel Alternator

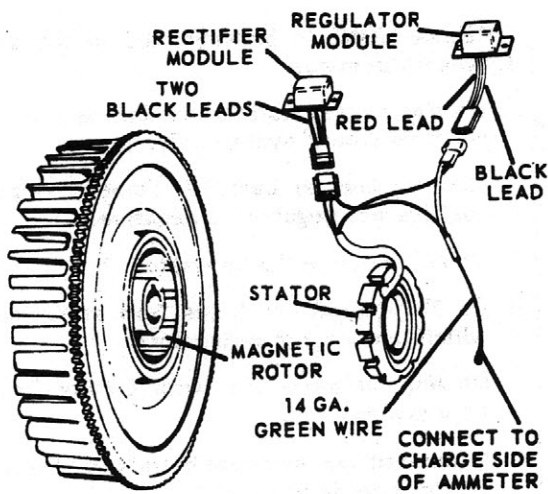

Fig. 1

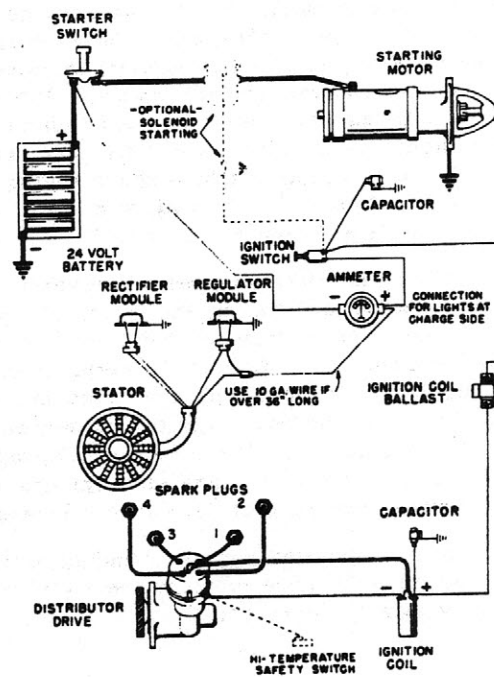

Fig. 2, WIRING CIRCUIT - With Radio Suppression

ENB101 (24 Volt - 15 Amp) Flywheel Alternator

SERVICE PROCEDURE:

Examine leads for broken or frayed wires, or loose connections. If none are found, disconnect battery and uncouple connectors joining stator and the two modules. Be sure base of modules is making contact with a good clean mounting surface on the engine, free of dirt, oil and grease. This will provide the necessary ground contact for the modules, as well as a means of dissipating heat.

TO CHECK STATOR: use an ohmmeter with R x 1 scale (minimum sensitivity of 20,000 ohms/volts), and check continuity as follows:

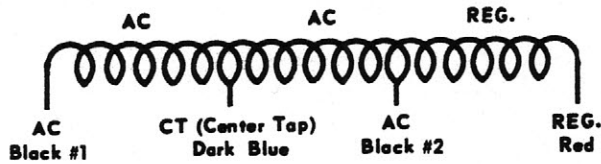

NOTE: Wire numbers for probe connections are for convenience only and are not indicated on the connectors.

METER PROBE CONNECTIONS		METER VALUE R X 1 SCALE	REPLACE STATOR
+	-		
Black #1 to Black #2		APPROX. 1.00 ohms	0 Indicates Short Circuit. ∞ Indicates Open Circuit.
Black #1 to CT		.50 ohm	
Black #2 to CT		.50 ohm	
Black #1 to Red		2.75 ohms	
Black #2 to Red		1.75 ohm	
Any Pin to Engine Ground		∞	Any reading indicates a short circuit.

TO CHECK RECTIFIER MODULE, Part No. YJ-64

The *rectifier* module can be distinguished from the *regulator* by the two black lead wires and identification decal. Use an ohmmeter and *static check* continuity as follows:

METER PROBE CONNECTIONS		CORRECT METER VALUE R X 1 SCALE	REPLACE RECTIFIER MODULE
+	-		
Eng. Gnd. to Black #1		5 to 15 ohms	Any read' indicates a short circuit.
Black #1 to Eng. Gnd.		∞	
Eng. Gnd. to Black #2		5 to 15 ohms	
Black #2 to Eng. Gnd.		∞	

TO CHECK REGULATOR MODULE, Part No. YJ- J.

The *regulator* module can be distinguished from the *rectifier* module by the lead wire colors, black and red, and the identification decal. Use a good ohmmeter and *static check* continuity as follows:

METER PROBE CONNECTIONS		CORRECT METER VALUE R X 1 SCALE	REPLACE REGULATOR MODULE
+	-		
Red	to Eng. Gnd.	∞	Any reading indicates a short circuit.
Eng. Gnd. to Red		∞	
Red	to Black	∞	
Black	to Red	∞	
Black	to Eng. Gnd.	∞	

Flywheel Alternator (12 Volt - 15 Amp)

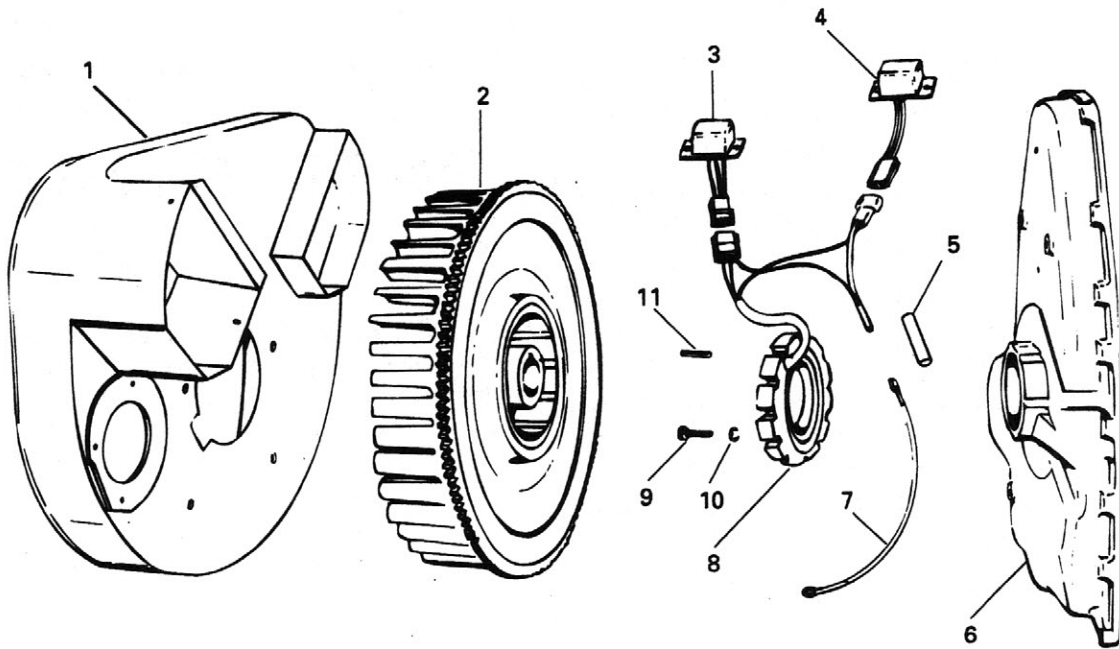

ITEM	PART NO.	DESCRIPTION	QTY	ITEM	PART NO.	DESCRIPTION	QTY
1	SE74YA	Flywheel shroud	1	9	XB106	Screw	4
2	N101-10	Flywheel	1	10	PE14	Lock washer, no. 10	4
3	YJ64	Rectifier module, 24 volt.....	1	11	PA340	Roll pin	2
4	YJ65	Regulator module, 24 volt	1	—	PD115	Nut, no. 10-32 thread (not illustrated)	4
5	YD350	Insulator	1	—	PE78A	Lock washer, no. 10 (not illustrated)	4
6	BD100K6S1	Gear cover assembly	1	—	XA8	Screw, no. 10-32 thread (not illustrated)	4
7	YL380-14	Wire assembly	1				
8	YB79	Stator assembly, 24 volt, 15 amp	1				

Flywheel Alternator (24 Volt - 15 Amp) (Obsolete)

Problem: Low/No Charge	Possible Cause & Remedy
Test 2.0 Conditions and procedure the same as Test 1.0 except the regulator module is disconnected. 2.1 If the charge rate increases - 2.2 If the charge rate does not increase -	2.1 Regulator was at fault. Replace regulator module. 2.2 Regulator is not at fault. Continue with Test 3.0.
Test 3.0 Test conditions and procedure the same as 1.0 except with new rectifier module plugged in. 3.1 If the charge rate increases - 3.2 If the charge rate does not increase -	3.1 Rectifier module at fault. Permanently install new rectifier module. 3.2 Continue with Test 4.0.
Test 4.0 With engine stopped, unplug all connectors between modules and stator. Start engine and run at 2400 RPM. With AC voltmeter check voltage between each of the black stator leads and ground. 4.1 If one of the two voltages is zero or they are over 10% apart -	4.1 The stator is faulty and should be replaced.

Further testing can be done on the component level with the engine stopped, and the stator and module connections including output lead uncoupled.

TO CHECK STATOR

Use an ohmmeter and check continuity as follows:

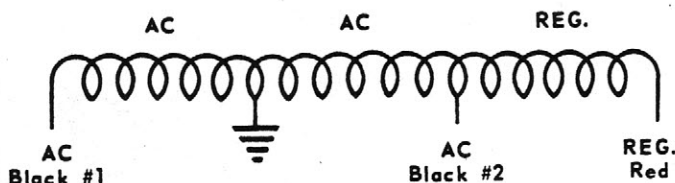

NOTE: Wire numbers indicated for probe connections are for convenience only and are not indicated on the connectors.

Flywheel Alternator (24 Volt - 15 Amp) (Obsolete)

For 10 amp unit STATOR

METER PROBE CONNECTIONS	METER VALUE	REPLACE STATOR
+ -		
Black #1 to Black #2	APPROX. 2.0 ohms	0 Indicates Short Circuit. ∞ Indicates Open Circuit.
Black #1 to Eng. Gnd.	1.0 ohm	
Black #2 to Eng. Gnd.	1.0 ohm	
Black #1 to Red	3.0 ohms	
Black #2 to Red	1.0 ohm	

For 25 amp unit STATOR

METER PROBE CONNECTIONS	METER VALUE	REPLACE STATOR
+ -		
Black #1 to Black #2	APPROX. 0.40 ohm	∞ Indicates Open Circuit.
Black #1 to Eng. Gnd.	0.20 ohm	
Black #2 to Eng. Gnd.	0.20 ohm	
Black #1 to Red	3.20 ohms	
Black #2 to Red	2.80 ohms	

STATOR IDENTIFICATION:

10 amp - 3/8" wide flange 25 amp - 5/8" wide flange

TO CHECK RECTIFIER MODULE, Part No. YJ-68

The same module is used for both the 10 amp and 25 amp systems. It can be distinguished from the regulator by the three lead wires instead of two and the identification decal. Use an ohmmeter and static check continuity as follows:

METER PROBE CONNECTIONS	METER INDICATION
+ -	
White lead to Black #1	No Continuity
Black #1 to White lead	Continuity
White lead to Black #2	No Continuity
Black #2 to White lead	Continuity

Note: Continuity shall be in one direction only. If readings are not as indicated, replace module.

TO CHECK REGULATOR MODULE, Part No. YJ-60

The same Regulator module is used for both the 10 amp and 25 amp systems. Use an Ohmmeter and static check as follows:

METER PROBE CONNECTIONS	METER INDICATION	REPLACE MODULE
+ -		
Red to Eng. Gnd.	No Continuity	Continuity
Eng. Gnd. to Red	↓	↓
Red to Black	↓	↓
Black to Red	↓	↓
Black to Eng. Gnd.	Continuity	No Continuity
Eng. Gnd. to Black	↓	↓

AMP OUTPUT regulated by engine speed

MODEL	MAXIMUM ENGINE SPEED	10 AMP SYSTEM	25 AMP SYSTEM
S-12D, S-14D	3600 RPM	10 amps	25 amps
AENL, TJD			
AGND	3200 RPM	10 amps	23 amps
VH4D	2800 RPM	9 amps	20 amps
VG4D	2400 RPM	8 amps	17 amps

Flywheel Alternator (12 Volt - 10 Amp And 25 Amp) (Obsolete)

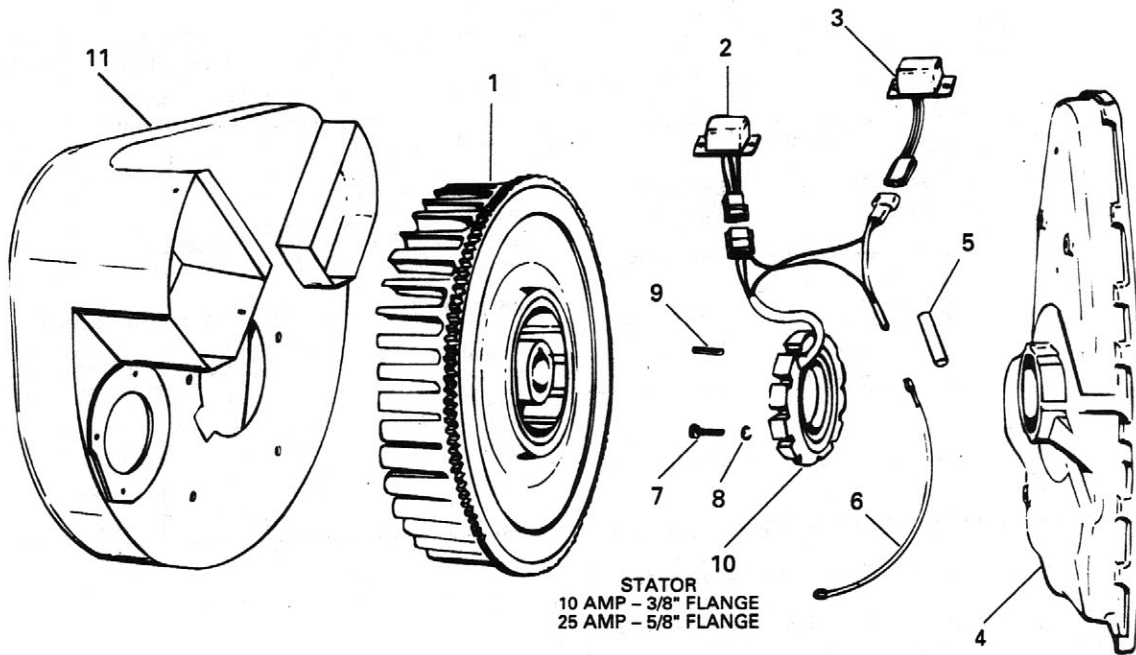

Flywheel Alternator (12 Volt – 10 Amp And 25 Amp) (Obsolete) (For Engines Beginning With Serial Number 5188288) (see pg. 22)

SERVICE PARTS LIST: The following items are in addition to, or replace similar parts found in the parts manual of each specific engine model. The parts illustration is for the VG4D engine, but can be applied to all models.

REF. NO.	DESCRIPTION	NO. REQ.	PART NUMBER PER ENGINE MODEL						
			AENL	AGND	S10D, S12D S14D	W2-880 THD, TJD	VF4D, VH4D	VG4D	W4-1770
1	* Flywheel, 10 amp	1	N104-5	N103-5	N105-2	N102-5	N101-6	N100-5	N101-17
	Flywheel, 25 amp	1	N104-9	N103-9	N105A3	N102-9	N101-10	N100-9	N101-16
2	Rectifier module	1	YJ68	YJ68	YJ68	YJ68	YJ68	YJ68	
3	Regulator module	1	YJ60	YJ60	YJ60	YJ60	YJ60	YJ60	
4	Gear cover assembly	1				BD103JS1	BD100K4S1	BD101BS1	BD100M1S1
	Bearing retainer plate	1	BG344S1	BG343S1	BG350AS1				
5	Insulator	1	YD350	YD350	YD350	YD350	YD350	YD350	
6	Wire assembly, 10 amp	1	YL381-6	YL381-6	YL381-18	YL381-14	YL381-18	YL381-22	
	Wire assembly, 25 amp	1	YL380-6	YL380-6	YL380-18	YL380-14	YL380-18	YL380-22	
7	Screw, 10 amp	4	XB114	XB113	XB113	XB113	XB113	XB113	
	Screw, 25 amp	4	XB110	XB106	XB106	XB106	XB106	XB106	
8	Lock washer, no. 10	4	PE14	PE14	PE14	PE14	PE14	PE14	
9	Roll pin, 10 amp	2	PA336	PA340		PA368	PA368	PA368	
	Roll pin, 25 amp	2	PA362	PA340		PA340	PA340	PA340	
10	Stator assembly, 10 amp	1	YB81	YB81	YB81	YB81	YB81	YB81	
	Stator assembly, 25 amp	1	YB82	YB82	YB82	YB82	YB82	YB82	
11	*Flywheel shroud	1	SE154A	SE217H	SE289A w/ SE301B1 Pl.	SE135AT	SE74YA	SE124AM	SE74YA

PARTS REQUIRED — NOT ILLUSTRATED

* Crankcase	1	AA91B10	BA54-20					
Engine base	1	BB128A5						
Clip	1	PG630-1	PG430					
Grommet	1			PH198B1				
Gasket	1	QD833						
Nut, no. 10-32 thread	4	PD115	PD115	PD115	PD115	PD115	PD115	PD115
Lock washer, no. 10	4	PE78A	PE78A	PE78A	PE78A	PE78A	PE78A	PE78A
Screw, no. 10-32 thread	4	XA7	XA7	XA7	XA8	XA8	XA8	XA8

*NOTE: Because of the available variations in Flywheels, Flywheel Shrouds and Crankcases — give Engine Model, Specification and Serial Numbers when ordering.

Flywheel Alternator (12 Volt – 10 Amp And 30 Amp) (Obsolete)

The improved Flywheel Alternator System (Page 26), with individual Rectifier and Regulator Modules, replaces this Single Unit Rectifier-Regulator System. FOR SERVICE: The Stator, Magnetic Rotor, Rectifier and Regulator are not interchangeable, and because of the 10 and 30 Amp Systems it is necessary that the Engine Model, Specification and Serial Numbers be given when ordering parts.

12 VOLT – 10 AMP ALTERNATOR

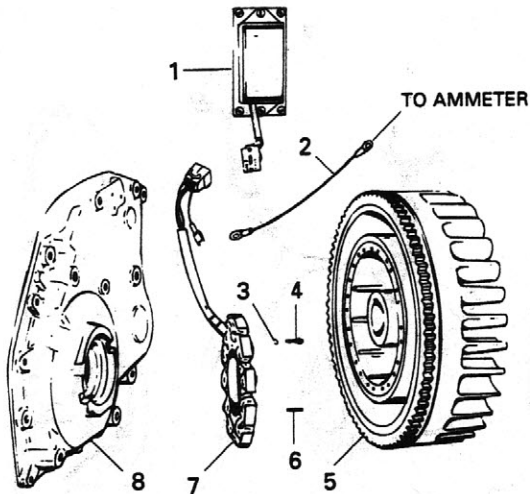

12 VOLT – 30 AMP ALTERNATOR

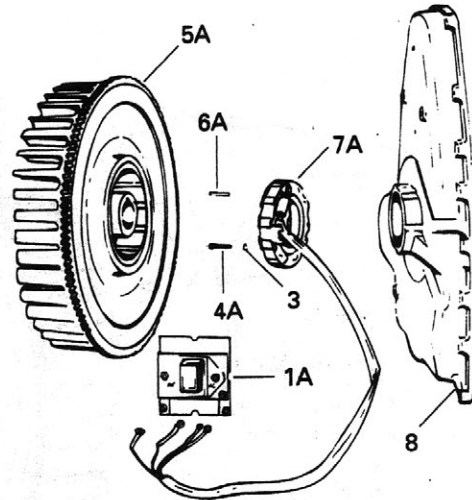

REF. NO.	DESCRIPTION	NO. REQ.	PART NUMBER PER ENGINE MODEL				
			AENL	AGND	THD, TJD	VE4D, VF4D, VH4D	VG4D
1 1A	Rectifier-regulator module, 10 amp Rectifier-regulator module, 30 amp	1 1	YJ56	YJ49S1	YJ56 YJ49S1	YJ56 YJ49S1	YJ56 YJ49S1
2	Wire assembly, 10 amp	1	YL379-14	YL379-14	YL379-14	YL379-14	YL379-18
3	Lock washer, no. 10	4	PE14	PE14	PE14	PE14	PE14
4 4A	Screw, 10 amp Screw, 30 amp	4 4	XB114	XB106	XB113 XB106	XB113 XB106	XB113 XB106
5 5A	* Flywheel, 10 amp Flywheel, 30 amp	1 1	N104-5	N103	N102-5 N102	N101-6 N101	N100-5 N100
6 6A	Roll pin, 10 amp Roll pin, 30 amp	2 2	PA336	PA340	PA368 PA340	PA368 PA340	PA368 PA340
7 7A	Stator assembly, 10 amp Stator assembly, 30 amp	1 1	YB72	YB67	YB72 YB67	YB72 YB67	YB72 YB67
8	Gear cover assembly Bearing retainer plate	1 1	BG344S1	BG343S1	BD103JS1	BD100K4S1	BD101BS1

***NOTE:** Because of the available variations in Flywheels and Flywheel Shrouds (not illustrated) — give Engine Model, Specification and Serial Numbers when ordering.

Flywheel Alternator (12 Volt – 10 Amp And 30 Amp) With Individual Rectifier and Regulator Modules

SERVICE PARTS LIST: The following items are in addition to, or replace similar parts found in the standard parts manual of each specific engine model. The parts illustration is for the VG4D engine, but can be applied to all models.

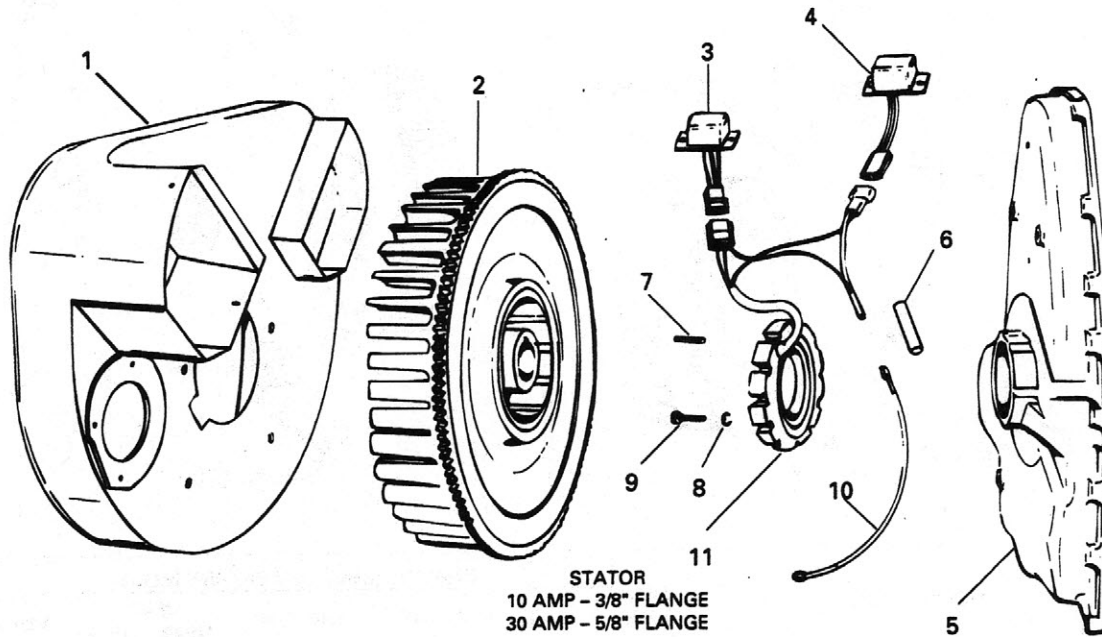

Flywheel Alternator (12 Volt – 10 Amp And 30 Amp) (see pg. 25)

REF. NO.	DESCRIPTION	NO. REQ.	PART NUMBER PER ENGINE MODEL					
			AENL	AGND	S10D, S12D	THD, TJD	VE4D VF4D, VH4D	VG4D
1	*Flywheel shroud	1	SE154A	SE217H	SE301B1 (back plate)	SE135AT	SE74YA	SE124AM
2	*Flywheel, 10 amp Flywheel, 30 amp	1	N104-5	N103-5	N105-2	N102-5	N101-6	N100-5
		1	N104-9	N103-9		N102-9	N101-10	N100-9
3	Rectifier module	1	YJ58	YJ58	YJ58	YJ58	YJ58	YJ58
4	Regulator module, 10 amp Regulator module, 30 amp	1	YJ59	YJ59	YJ59	YJ59	YJ59	YJ59
		1	YJ60	YJ60		YJ60	YJ60	YJ60
5	Gear cover assembly Bearing retainer plate	1				BD103JS1	BD100K4S1	BD101BS1
		1	BG344S1	BG343S1	BG350AS1			
6	Insulator	1	YD350	YD350	YD350	YD350	YD350	YD350
7	Roll pin, 10 amp Roll pin, 30 amp	2	PA336	PA340		PA368	PA368	PA368
		2	PA362	PA340		PA340	PA340	PA340
8	Lock washer, no. 10	4	PE14	PE14	PE14	PE14	PE14	PE14
9	Screw, 10 amp Screw, 30 amp	4	XB114	XXB113	XB113	XB113	XB113	XB113
		4	XB110	XB106		XB106	XB106	XB106
10	Wire assembly, 10 amp Wire assembly, 30 amp	1	YL381-6	YL381-6	YL381-18	YL381-14	YL381-14	YL381-18
		1	YL380-6	YL380-6		YL380-14	YL380-14	YL380-18
11	Stator assembly, 10 amp Stator assembly, 30 amp	1	YB75	YB75	YB75	YB75	YB75	YB75
		1	YB76	YB76		YB76	YB76	YB76

PARTS REQUIRED — NOT ILLUSTRATED

*Crankcase	1	AA91B1	BA54-20					
Engine base	1	BB128A5						
Clip	1	PG630-1	PG430					
Gasket	1	QD833						
Nut, no. 10-32 thread	4	PD115	PD115	PD115	PD115	PD115	PD115	PD115
Lock washer, no. 10	4	PE78A	PE78A	PE78A	PE78A	PE78A	PE78A	PE78A
Screw, no. 10-32 thread	4	XA7	XA7	XA7	XA8	XA8	XA8	XA8

***NOTE:** Because of the available variations in Flywheels, Flywheel Shrouds and Crankcases — give Engine Model, Specification and Serial Numbers when ordering these parts.

Flywheel Alternator (12 Volt – 10 Amp And 25 Amp) (With Solid State Regulation) (Single, Two And Four Cylinder Engine Models)

DESCRIPTION of Change

Beginning with engine serial No. 5188288, a new *two module* flywheel alternator system replaces the previously furnished three module system, that included an isolation diode module, and the two unit system without the isolation diode.

The *isolation diode* module was incorporated into the old system to eliminate battery discharge problems during shut down, cranking and idling.

INTERCHANGEABILITY

The *Regulator module* was not changed and is completely interchangeable between the new and old systems. The *Rectifier module* and *Stator assembly* have been modified to incorporate the advantages of an isolation diode without adding a third module. These new parts are *not* interchangeable with the old unless both rectifier and stator are replaced simultaneously. The new system has a *three prong* plug connector between the rectifier and stator – the old system has a two prong connector.

DESCRIPTION and OPERATION

This flywheel alternator is of the permanent magnet type and has *no brushes, commutator, belts or adjustments*. A series of coils (stator) is mounted to the engine gear cover, and the magnetic flux is provided by a permanent magnet in the flywheel which rotates around these stationary coils. Only four components make up this light weight space saving system; a *flywheel* with magnetic rotor, *stator*, *rectifier* module and *regulator* module.

The *center-tap* rectifier arrangement prevents damage to the alternator system when arc welding, because the winding acts as a choke and its inductance prevents the transient voltage from damaging the diodes.

Since the physical appearance of both 10 amp and 25 amp alternator systems are very similar, the 25 amp

unit can be distinguished from the 10 amp unit by the ammeter calibrations, and by a 14 gage green wire in place of a 16 gage red wire, from the ammeter to the stator-regulator connector.

PRECAUTIONS to be exercised in the use of this flywheel alternator:

1. **Do Not** reverse battery connections. This is for a *negative ground* system only.
2. Connect booster batteries properly – positive to positive and negative to negative.
3. **Do Not** polarize the alternator.
4. **Do Not** ground any wires from stator or modules which terminate at connectors.
5. **Do Not** operate engine with battery disconnected from system.
6. Disconnect at least one battery lead if a battery charger is used.

WIRING CIRCUIT

The *fool-proof* type connectors used prevent incorrect wiring from the stator to the rectifier and regulator modules. To disconnect plugs, squeeze outer ends of receptical and pull apart.

The rectifier is insulated from ground, but the stator and regulator module are grounded to the engine thru their mounting surface. The regulator module therefore should not be removed and mounted at some remote location. This is a *negative ground circuit*. Connect ground strap from negative post of battery to starting motor flange, or good clean grounding surface on engine.

Flywheel Alternator (12 Volt - 10 Amp And 25 Amp) (With Solid State Regulation) (Single, Two And Four Cylinder Engine Models)

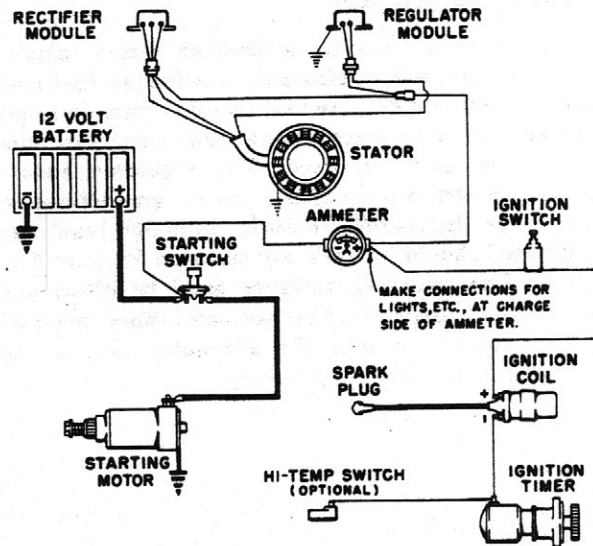
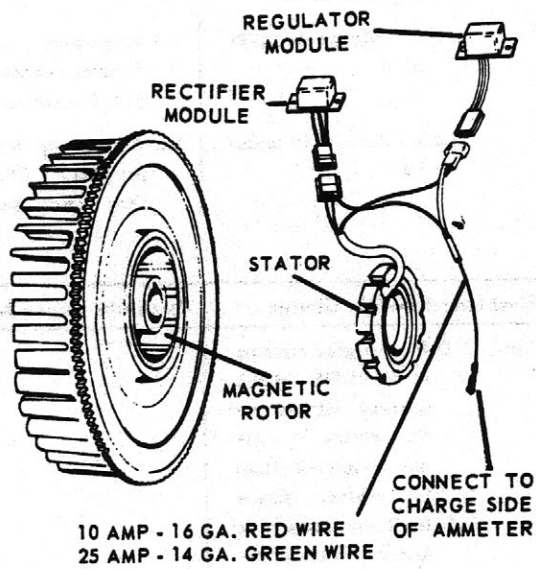

WIRING DIAGRAM
For Single Cylinder Models

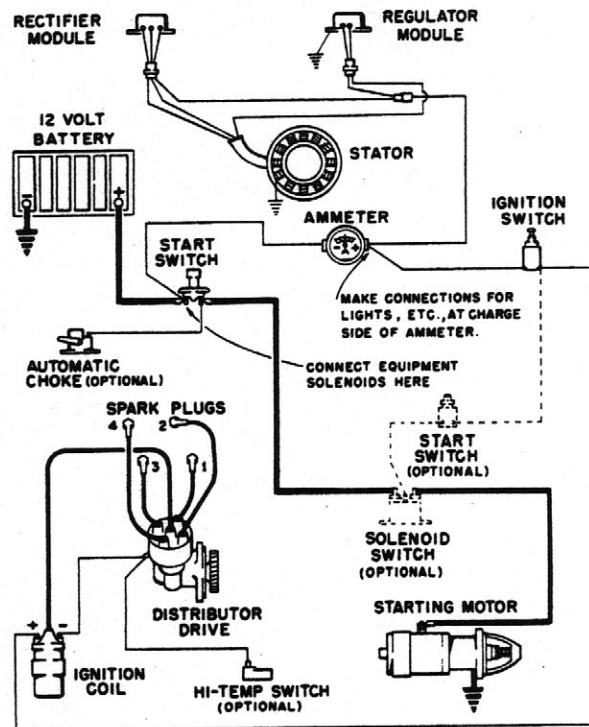

WIRING DIAGRAM
For Two and Four Cylinder Models

Flywheel Alternator (12 Volt – 10 Amp And 25 Amp) (With Solid State Regulation) (Single, Two And Four Cylinder Engine Models)

SERVICE PROCEDURE:

Prior to electrical testing, a thorough visual inspection should be made to eliminate conditions that may be interpreted as a defected alternator. Examine leads for broken or loose connections, and make sure modules are securely mounted. The *regulator module* must be mounted to a metal surface for grounding purposes, while the *rectifier module*, although insulated from ground, should be securely mounted for heat dissipation. The mounting surfaces must be clean and free of contaminants, oil, grease, etc. When assured that the problem is with the alternator, follow the tests outlined in 'Trouble Shooting'.

TROUBLE SHOOTING

10 and 25 amp Flywheel Alternator

Problem: Battery Overcharge	Possible Cause & Remedy
Test 1.0 With engine running at full RPM, check battery voltage w/ DC Voltmeter.	
1.1 If voltage is over 15.0	1.1 Regulator not functioning properly. Replace module.
1.2 If voltage is under 15	1.2 Alternator functioning properly. Check battery condition.

Problem: Low/No Charge	Possible Cause & Remedy
Test 1.0 With engine running at full RPM, check battery voltage w/ DC meter. If voltage is greater than 14 volts, place * load on battery to reduce voltage below 14 volts.	
1.1 If the charge rate increases –	1.1 Alternator functioning properly. Battery was fully charged.
1.2 If the charge rate does not increase–	1.2 Proceed with Test 2.0.

* Place as many 12 volt light bulbs across battery as required to reduce voltage below 14 volts. A carbon pile resistor may be used in place of bulbs.

Flywheel Alternator (12 Volt – 10 Amp And 30 Amp) (With Solid State Regulation) (Single, Two And Four Cylinder Engine Models)

This flywheel alternator is of the permanent magnet type and has *no brushes, commutator, belts or adjustments*. A series of coils (stator) is mounted to the engine gear cover, and the magnetic flux is provided by a permanent magnet in the flywheel which rotates around these stationary coils. Four components make up this light weight – space saving source of energy as illustrated below, a *flywheel* with magnetic rotor, *stator*, *rectifier* module and *regulator* module.

The *center-top* rectifier arrangement prevents damage to the alternator system, in the event of incorrect battery connection or by arc welding. One half of the load-producing winding is in series with each diode, so when the battery is connected in reverse, resistance of the winding limits the current draw and keeps it at a safe level. If the incorrect battery connection is not remedied, complete drainage of the battery occurs, but the rectifier will not be damaged.

In the case of arc welding, the winding acts as a choke and its inductance prevents the transient voltage from damaging the diodes.

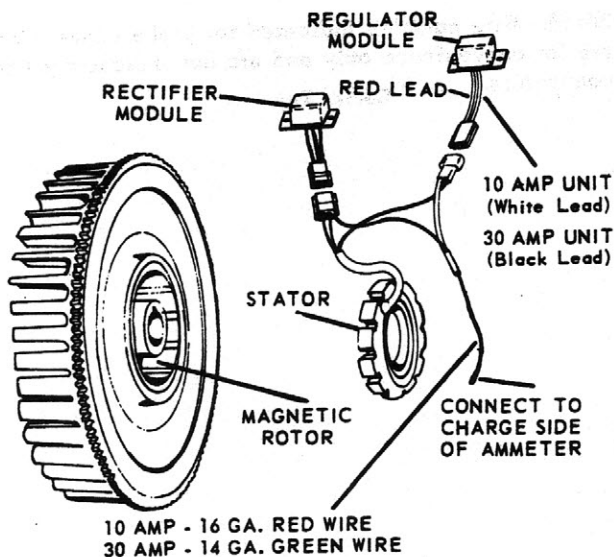

Since the physical appearance of both alternators is very similar, the 12 volt – 30 amp unit can be distinguished from the 10 amp unit by the ammeter calibrations, and by a 14 gage green wire in place of a 16 gage red wire, from the ammeter to the stator-regulator connector. Also, by the contrasting colors of the two lead wires emanating from the regulator module. The 10 amp regulator has white and red leads, the 30 amp black and red.

PRECAUTIONS to be exercised in the use of this flywheel alternator:

1. **Do Not** reverse battery connections. This is for a *negative ground* system only.
2. Connect booster batteries properly – positive to positive and negative to negative.
3. **Do Not** polarize the alternator.
4. **Do Not** ground any wires from stator or modules which terminate at connectors.
5. **Do Not** operate engine with battery disconnected from system.
6. Disconnect at least one battery lead if a battery charger is used.
7. Never use a fast battery charger to boost the battery output.

WIRING CIRCUIT

The *fool-proof* type connectors used, prevent incorrect wiring from the stator to the rectifier and regulator modules. To disconnect plugs, squeeze outer ends of receptical and pull apart.

The rectifier and regulator modules are grounded to the engine and therefore should not be removed and mounted at some remote location. This is a *negative ground circuit*. Connect ground strap from negative post of battery to starting motor flange, or good clean grounding surface on engine.

Flywheel Alternator (12 Volt – 10 Amp And 30 Amp) (With Solid State Regulation) (Single, Two And Four Cylinder Engine Models)

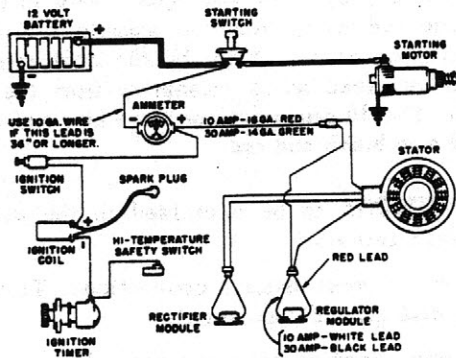

WIRING DIAGRAM
For Single Cylinder Models

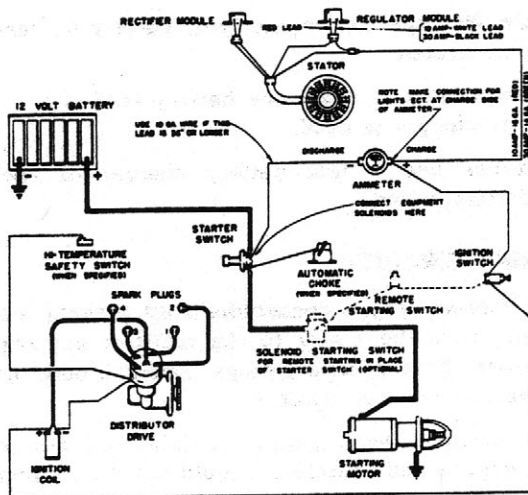

WIRING DIAGRAM
For Two and Four Cylinder Models

SERVICE PROCEDURE:

Examine leads for broken or frayed wires, or loose connections. If none are found, disconnect battery and uncouple connectors joining stator and the two modules. Make sure mounting face (base of modules), is making proper contact with engine. It is imperative that the modules be properly secured to the mounting surface, since this is their ground connection. Heat is also dissipated from the modules thru its mounting, therefore the surface must be clean and free of contaminants, oil, grease, etc.

TO CHECK STATOR

Use an ohmmeter with R x 1 scale (minimum sensitivity of 20,000 ohms/volts), and check continuity as follows:

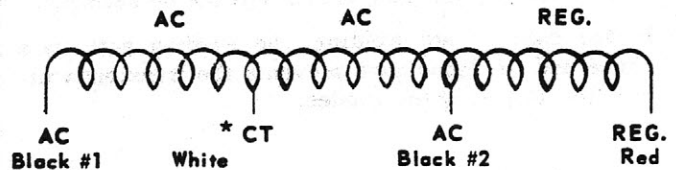

NOTE: Wire numbers indicated for probe connections are for convenience only and are not indicated on the connectors.

* Center Tap

Flywheel Alternator (12 Volt – 10 Amp And 30 Amp) (With Solid State Regulation) (Single, Two And Four Cylinder Engine Models)

FOR 10 AMP UNIT STATOR

METER PROBE CONNECTIONS		METER VALUE	REPLACE STATOR
+	-	R X 1 SCALE	
Black #1 to Black #2		APPROX.	0 Indicates Short Circuit. ∞ Indicates Open Circuit.
Black #1 to CT			
Black #2 to CT			
Black #1 to Red			
Black #2 to Red			
Any Pin to Engine Ground		∞	Any reading indicates a short circuit.

FOR 30 AMP UNIT STATOR

METER PROBE CONNECTIONS		METER VALUE	REPLACE STATOR
+	-	R X 1 SCALE	
Black #1 to Black #2		APPROX.	∞ Indicates Open Circuit.
Black #1 to CT			
Black #2 to CT			
Black #1 to Red			
Black #2 to Red			
Any Pin to Engine Ground		∞	Any reading indicates a short circuit.

STATOR IDENTIFICATION:

10 amp – 3/8" wide flange 30 amp – 5/8" wide flange

TO CHECK RECTIFIER MODULE, Part No. YJ-58

The same module is used for both the 10 amp and 30 amp circuits. It can be distinguished from the *regulator* by the two black lead wires and identification decal. Use an ohmmeter and static check continuity as follows:

METER PROBE CONNECTIONS		CORRECT METER VALUE	REPLACE RECTIFIER MODULE
+	-	R X 1 SCALE	
Eng. Gnd. to Black #1		5 to 15 ohms ∞	Any reading indicates a short circuit.
Black #1 to Eng. Gnd.			
Eng. Gnd. to Black #2			
Black #2 to Eng. Gnd.			

TO CHECK REGULATOR MODULE

Part No. YJ-59 for 10 amp circuit, YJ-60 for 30 amp.

The *regulator module* can be distinguished from the *rectifier module* by the lead wire colors and identification decal. The 10 amp unit has a **WHITE WIRE** and a **RED WIRE** leading to the socket connector, whereas the 30 amp regulator has **BLACK** and **RED** lead wires. Use a good ohmmeter and static check continuity as follows:

METER PROBE CONNECTIONS		10 Amp Unit 30 Amp Unit		CORRECT METER VALUE	REPLACE REGULATOR MODULE
+	-	10 Amp Unit	30 Amp Unit	R X 1 SCALE	
Red	to Eng. Gnd.	x	x	∞	Any reading indicates a short circuit.
Eng. Gnd.	to Red	x	x	∞	
Red	to White	x	x	∞	
White	to Red	x	x	∞	
White	to Eng. Gnd.	x	x	∞	
Red	to Black	x	x	∞	
Black	to Red	x	x	∞	
Black	to Eng. Gnd.	x	x	∞	

DF83 Analyzer

YJ65 REGULATOR

Module is defective if lamp indication is not as specified

TEST NO.	ANALYZER RED LEAD TO:	ANALYZER BLACK LEAD TO:	ANALYZER WHITE LEAD TO:	LAMP INDICATION
1	Module Base Plate	Module Red Lead	-	Off
2	Module Red Lead	Module Base Plate	-	Off

3	Module Black Lead	Module Base Plate	-	Off
4	Module Base Plate	Module Black Lead	-	On

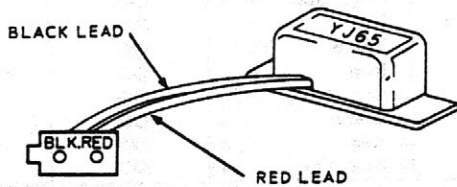

YJ68 RECTIFIER

Module is defective if lamp indication is not as specified

TEST NO.	ANALYZER RED LEAD TO:	ANALYZER BLACK LEAD TO:	ANALYZER WHITE LEAD TO:	LAMP INDICATION
1	Module White Lead	Either Module Black Lead	-	Off
2	Module White Lead	Other Module Black Lead	-	Off
3	Either Module Black Lead	Module White Lead	-	On
4	Other Module Black Lead	Module White Lead	-	On
5	Module Base Plate	Module White Lead	-	Off

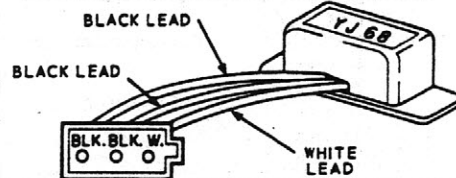

YJ56 RECTIFIER / REGULATOR

Module is defective if lamp indication is not as specified

TEST NO.	ANALYZER RED LEAD TO:	ANALYZER BLACK LEAD TO:	ANALYZER WHITE LEAD TO:	LAMP INDICATION
1	Either Module Black Lead	Module Heat Sink	-	Off
2	Other Module Black Lead	Module Heat Sink	-	Off
3	Module Heat Sink	Either Module Black Lead	-	On
4	Module Heat Sink	Other Module Black Lead	-	On
5	Module Heat Sink	Module Red Lead	-	Off
6	Module Red Lead	Module Heat Sink	-	Off
7	Module White Lead	Module Heat Sink	-	Off
8	Module Heat Sink	Module White Lead	-	On

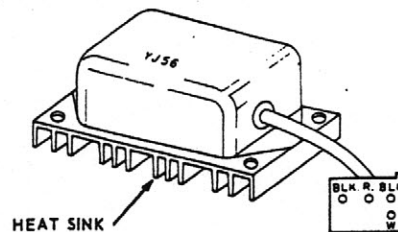

YJ58 and YJ64 RECTIFIER

Module is defective if lamp indication is not as specified

TEST NO.	ANALYZER RED LEAD TO:	ANALYZER BLACK LEAD TO:	ANALYZER WHITE LEAD TO:	LAMP INDICATION
1	Either Module Black Lead	Module Base Plate	-	Off
2	Other Module Black Lead	Module Base Plate	-	Off
3	Module Base Plate	Either Module Black Lead	-	On
4	Module Base Plate	Other Module Black Lead	-	On

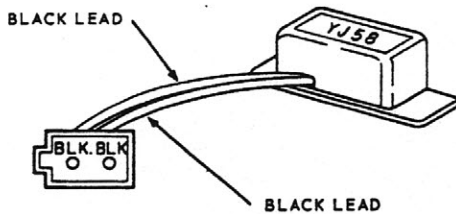

DF83 Analyzer

OPERATION

The DF83 Analyzer was developed for testing the solid state ignition and flywheel alternator components as furnished on Wisconsin engines. It is very efficiently and economically powered by four transistor radio type 9 volt batteries.

Caution: Turn analyzer switch to *off* position when not in use, to prevent any unnecessary drain on the batteries. **Do Not** allow Indicator Light to burn unnecessarily for any length of time – the 10 volt bulb as used in the 36 volt test system will heat up and burn out.

Heavy duty type batteries should last about one year with normal use, but it is suggested that periodically a voltmeter be used to check the battery output – Test batteries as follows:

Analyzer Black Lead to Red Lead 27 volts – when voltage drops to 24 volts, replace batteries.

Analyzer Black Lead to White Lead 36 volts – when voltage drops to 32 volts, replace batteries.

To replace batteries; Remove cover and use a pen knife to peel off foam rubber insulating tape, so that batteries can be individually disconnected and removed. Tape batteries together in reassembly.

To remove indicator lamp; unscrew knurled nut and pull bulb outward – use exact replacement.

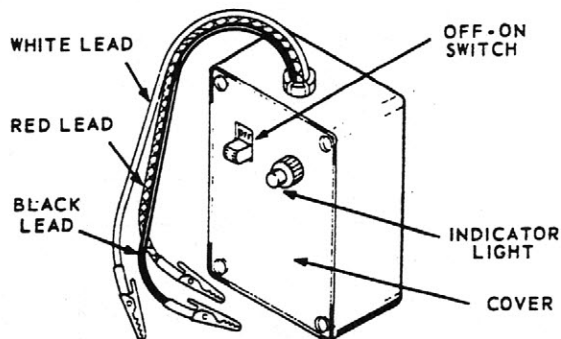

DF83 ANALYZER

TESTING PROCEDURES

YJ59 REGULATOR

Module is defective if lamp indication is not as specified

TEST NO.	ANALYZER RED LEAD TO:	ANALYZER BLACK LEAD TO:	ANALYZER WHITE LEAD TO:	LAMP INDICATION
1	Module Base Plate	Module Red Lead	-	Off
2	Module Red Lead	Module Base Plate	-	Off
3	Module Red Lead	Module Base Plate	Module White Lead Then Remove	On And Remain On

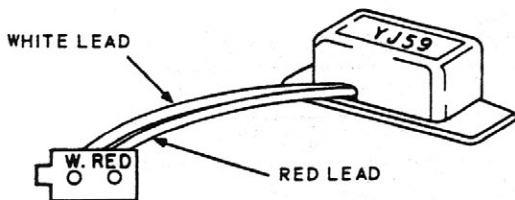

YJ60 REGULATOR

Module is defective if lamp indication is not as specified

TEST NO.	ANALYZER RED LEAD TO:	ANALYZER BLACK LEAD TO:	ANALYZER WHITE LEAD TO:	LAMP INDICATION
1	Module Base Plate	Module Red Lead	-	Off
2	Module Red Lead	Module Base Plate	-	Off
3	Module Black Lead	Module Base Plate	-	Dim
4	Module Base Plate	Module Black Lead	-	On

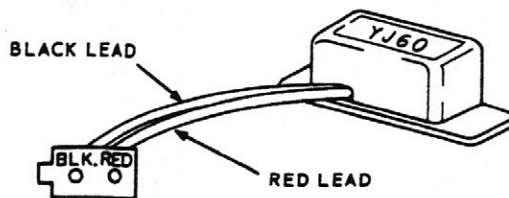

DF83 Analyzer

ROBIN EY-21W EY 2107130120 RECTIFIER

Module is defective if lamp indication is not as specified

TEST NO.	ANALYZER RED LEAD TO:	ANALYZER BLACK LEAD TO:	ANALYZER WHITE LEAD TO:	LAMP INDICATION
1	Brown Terminal	Blue Terminal	-	Off
2	Blue Terminal	Brown Terminal	-	On
3	Yellow Terminal	Blue Terminal	-	Off
4	Blue Terminal	Yellow Terminal	-	On
5	Red Terminal	Brown Terminal	-	Off
6	Brown Terminal	Red Terminal	-	On
7	Red Terminal	Yellow Terminal	-	Off
8	Yellow Terminal	Red Terminal	-	On

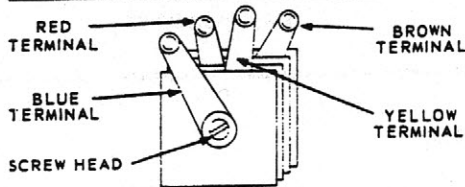

STATORS

The continuity tests for stators is not a 100% method of checking. However, if the stator fails the continuity tests, it is definitely defective. If it passes the tests but all other components have also checked out O.K., the stator may be the defective part of the system and should be replaced. Test can be made with Stator on engine.



Stator is defective if lamp indication is not as specified

YB83 STATOR

TEST NO.	ANALYZER RED LEAD TO:	ANALYZER BLACK LEAD TO:	ANALYZER WHITE LEAD TO:	LAMP INDICATION
1	Stator Blue Lead	Stator Black Lead	-	On
2	Stator Yellow Lead	Stator Black Lead	-	On (Dim)
3	Stator Blue Lead	Ground	-	Off
4	Stator Yellow Lead	Ground	-	Off

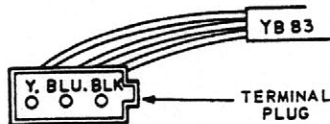

YB81 10 amp STATOR YB82 25 amp STATOR

TEST NO.	ANALYZER RED LEAD TO:	ANALYZER BLACK LEAD TO:	ANALYZER WHITE LEAD TO:	LAMP INDICATION
1	Stator Black Lead	Ground	-	On
2	Stator Other Black Lead	Ground	-	On
3	Ground	Stator Red Lead	-	On
4	Ground	Stator Black Lead	-	On
5	Ground	Stator Other Black Lead	-	On

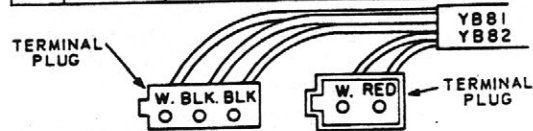

YB75 10 amp STATOR YB76 30 amp STATOR

TEST NO.	ANALYZER RED LEAD TO:	ANALYZER BLACK LEAD TO:	ANALYZER WHITE LEAD TO:	LAMP INDICATION
1	-	Laminated Flange	Stator Black Lead	Off
2	-	Laminated Flange	Stator Other Black Lead	Off
3	Stator Black Lead	Stator White Lead	-	On
4	Stator Other Black Lead	Stator White Lead	-	On
5	Stator Red Lead	Stator White Lead	-	On

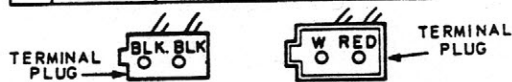

YB72 STATOR

TEST NO.	ANALYZER RED LEAD TO:	ANALYZER BLACK LEAD TO:	ANALYZER WHITE LEAD TO:	LAMP INDICATION
1	-	Laminated Flange	Stator Black Lead	Off
2	-	Laminated Flange	Stator Other Black Lead	Off
3	Stator Black Lead	Stator White Lead	-	On
4	Stator Other Black Lead	Stator White Lead	-	On
5	Stator Red Lead	Stator White Lead	-	On

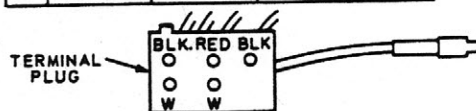

DF83 Analyzer

YJ49 RECTIFIER/REGULATOR

Module is defective if lamp indication is not as specified

TEST NO.	ANALYZER RED LEAD TO:	ANALYZER BLACK LEAD TO:	ANALYZER WHITE LEAD TO:	LAMP INDICATION
1	Either AC Terminal	Module BAT. NEG. Terminal	-	Dim
2	Other AC Terminal	Module BAT. NEG. Terminal	-	Dim
3	Module BAT. NEG. Terminal	Either AC Terminal	-	On
4	Module BAT. NEG. Terminal	Other AC Terminal	-	On
5	BAT. +/REG. Terminal	Either AC Terminal	-	Dim
6	BAT. +/REG. Terminal	Other AC Terminal	-	Dim
7	Either AC Terminal	BAT. +/REG. Terminal	-	On
8	Other AC Terminal	BAT. +/REG. Terminal	-	On
9	Module BAT. NEG. Terminal	REG. Terminal	-	Off

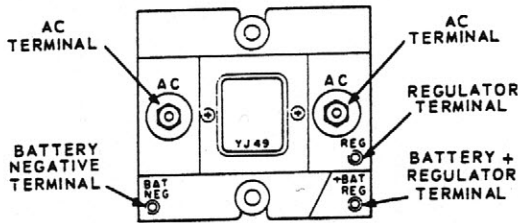

YJ67 ISOLATION DIODE

Module is defective if lamp indication is not as specified

TEST NO.	ANALYZER RED LEAD TO:	ANALYZER BLACK LEAD TO:	ANALYZER WHITE LEAD TO:	LAMP INDICATION
1	Module Red Lead	Module White Lead	-	Off
2	Module White Lead	Module Red Lead	-	On
3	Module White Lead	Module Base Plate	-	Off

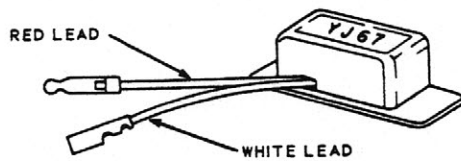

YJ69 IGNITION MODULE

Module is defective if lamp indication is not as specified

TEST NO.	ANALYZER RED LEAD TO:	ANALYZER BLACK LEAD TO:	ANALYZER WHITE LEAD TO:	LAMP INDICATION
1	Module Yellow Lead	Module Case or Black Lead	-	Off
2	Module Yellow Lead	Module Case or Black Lead	Module Blue Lead Then Remove	On And Remain On
3	Module Case	Module Yellow Lead	-	On
4	Module Case	Module Blue Lead	-	On
5	Module Case	Module Red Lead	-	Off
6	Module Red Lead	Module Case or Black Lead	-	On
7	Module Yellow Lead	Module Red Lead	-	Off

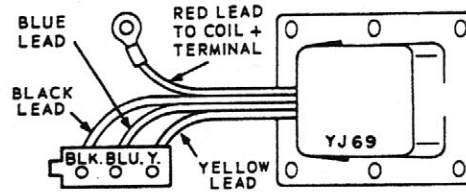

ROBIN EY-44W EY 2087130101 RECTIFIER

Module is defective if lamp indication is not as specified

TEST NO.	ANALYZER RED LEAD TO:	ANALYZER BLACK LEAD TO:	ANALYZER WHITE LEAD TO:	LAMP INDICATION
1	Light Blue Terminal	Stud	-	Off
2	Stud	Light Blue Terminal	-	On
3	Violet Terminal	Stud	-	Off
4	Stud	Violet Terminal	-	On
5	Gray Terminal	Light Blue Terminal	-	Off
6	Light Blue Terminal	Gray Terminal	-	On
7	Gray Terminal	Violet Terminal	-	Off
8	Violet Terminal	Gray Terminal	-	On

